

RC helicopter

PRÔTOS *Mini*

instructions manual

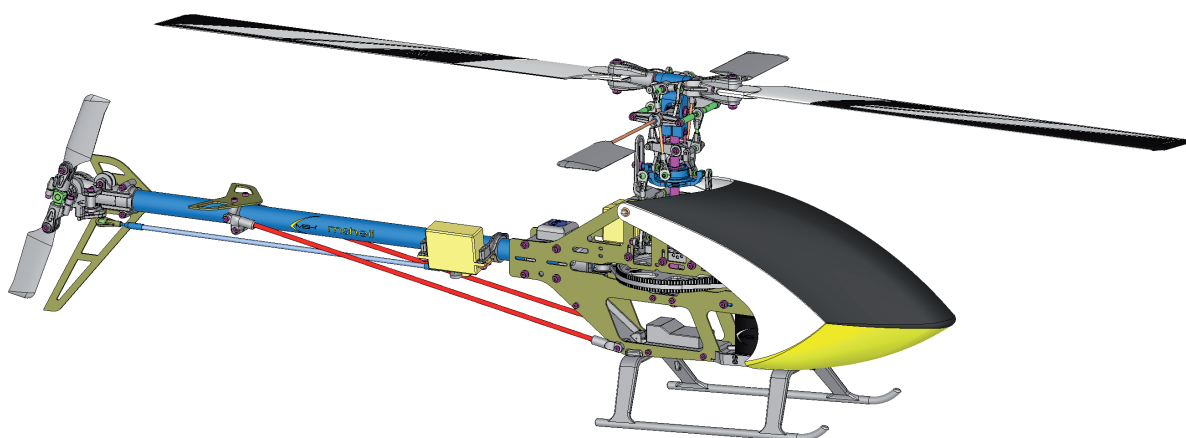

Main rotor diameter:	736mm
Tail rotor diameter:	157mm
Length without main blades:	714mm
Length with main blades:	879mm
Main blades length:	325mm
Overall height:	233mm
Tail rotor-Main rotor ratio:	4,29
Main pulley:	120T
Weight AUV without battery:	635gr

RC helicopter Instruction Manual

Index

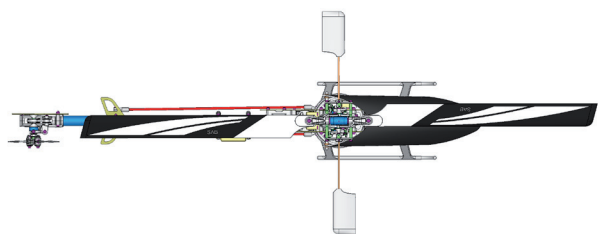
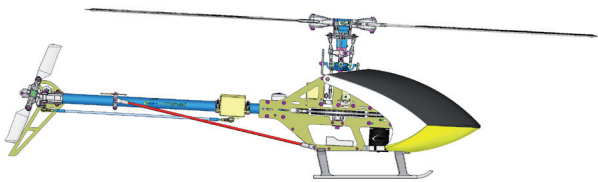

3	safety rules
4	assembly tools required
5	R/C equipment required for assembly
6	motor pinion teeth choice
7-13	main frame assembly
14-22	flybarred head assembly
23-26	flybarless head assembly
27-37	tail assembly
38-40	motor installation
41-42	battery, ESC and canopy installation
42	belt tensioning diagram
43-46	spare parts listing

Always follow these rules for safety

Operate the helicopter in open areas with no people nearby.

Do NOT operate the helicopter in the following places and situations (or else you risk severe accidents):

- in places where children gather or people pass through
- in residential areas and parks
- indoors and in limited space
- in windy weather or when there is rain, snow, fog or other precipitation

If you do not observe these instructions you may be held liable for personal injury or property damage!

Always check the R/C system prior to operating your helicopter.

When the R/C system batteries get weaker, the operational range of the R/C system decreases.

Note that you may lose control of your model when operating it under such conditions.

Keep in mind that other people around you might also be operating a R/C model.

Never use a frequency which someone else is using at the same time.

Radio signals will be mixed and you will lose control of your model.

If the model shows irregular behavior, bring the model to a halt immediately and disconnect the batteries. Investigate the reason and fix the problem.

Do not operate the model again as long as the problem is not solved, as this may lead to further trouble and unforeseen accidents.

In order to prevent accidents and personal injury, be sure to observe the following:

Before flying the helicopter, ensure that all screws are tightened.

A single loose screw may cause a major accident.

Replace all broken or defective parts with new ones, as damaged parts lead to crashes.

Never approach a spinning rotor. Keep at least 10 meters/yards away from a spinning rotor blades.

Do not touch the motor immediately after use. It may be hot enough to cause burns.

Perform all necessary maintenance.

PRIOR TO ADJUSTING AND OPERATING YOUR MODEL, OBSERVE THE FOLLOWING

Operate the helicopter only outdoors and out of people's reach as the main rotor operates at high rpm!

While adjusting, stand at least 10 meters

Novice R/C helicopter pilots should always seek advice from experienced pilots to obtain hints with assembly and for pre-flight adjustments.



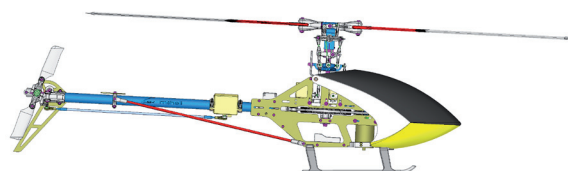

Note that a badly assembled or insufficiently adjusted helicopter is a safety hazard!

In the beginning, novice R/C helicopter pilots should always be assisted by an experienced pilot and never fly alone!

MSHeli Srl
Italy

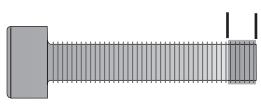

Tools required for assembly

 <p>1.5 / 2 / 2.5 mm Hexagon screw drivers</p>	 <p>Philips Screw driver</p>
 <p>Needle nose pliers</p>	 <p>Slow curing EPOXY</p>
 <p>where indicated use</p>  <p>Thread lock MEDIUM (blue)</p>	

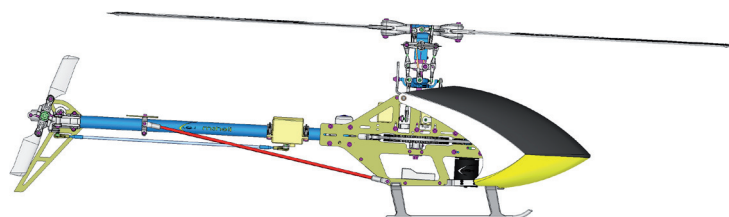

R/C equipment required for assembly

3 micro servos

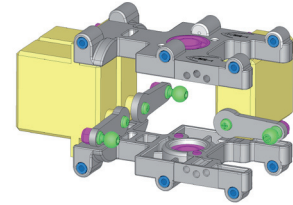

1 gyro servo micro/mini

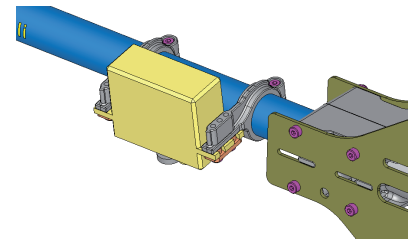

1 receiver

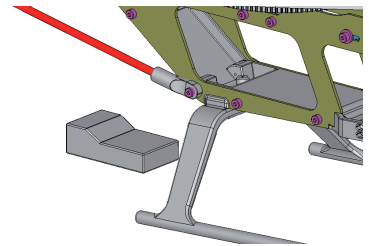

1 gyro

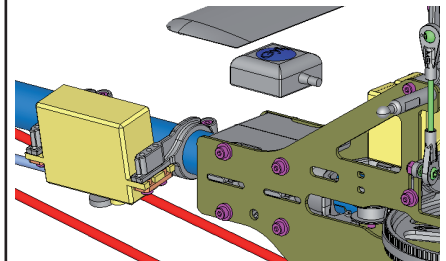

1 battery 3S 2000-2500mah

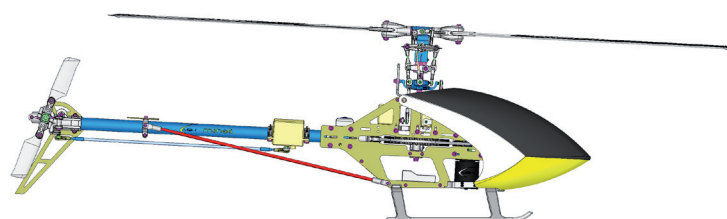
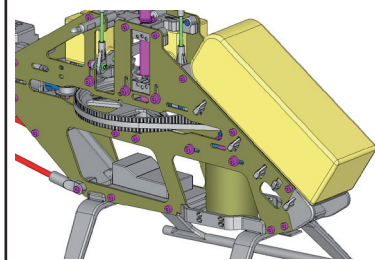

Motor pinion teeth choice

Fly style	Battery type 3s
Beginner	14-15
Sport	15-16
Soft 3D	16
Hard 3D	17

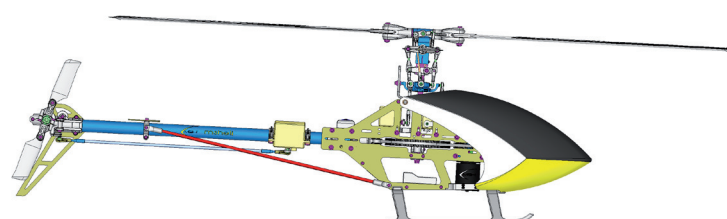
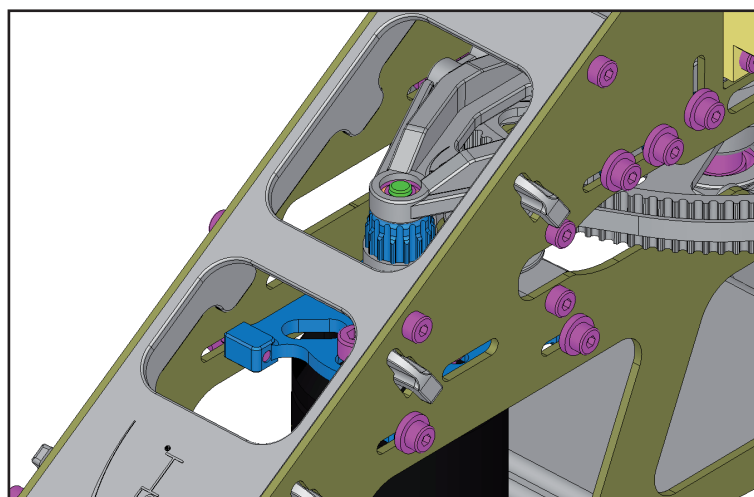

BAG A

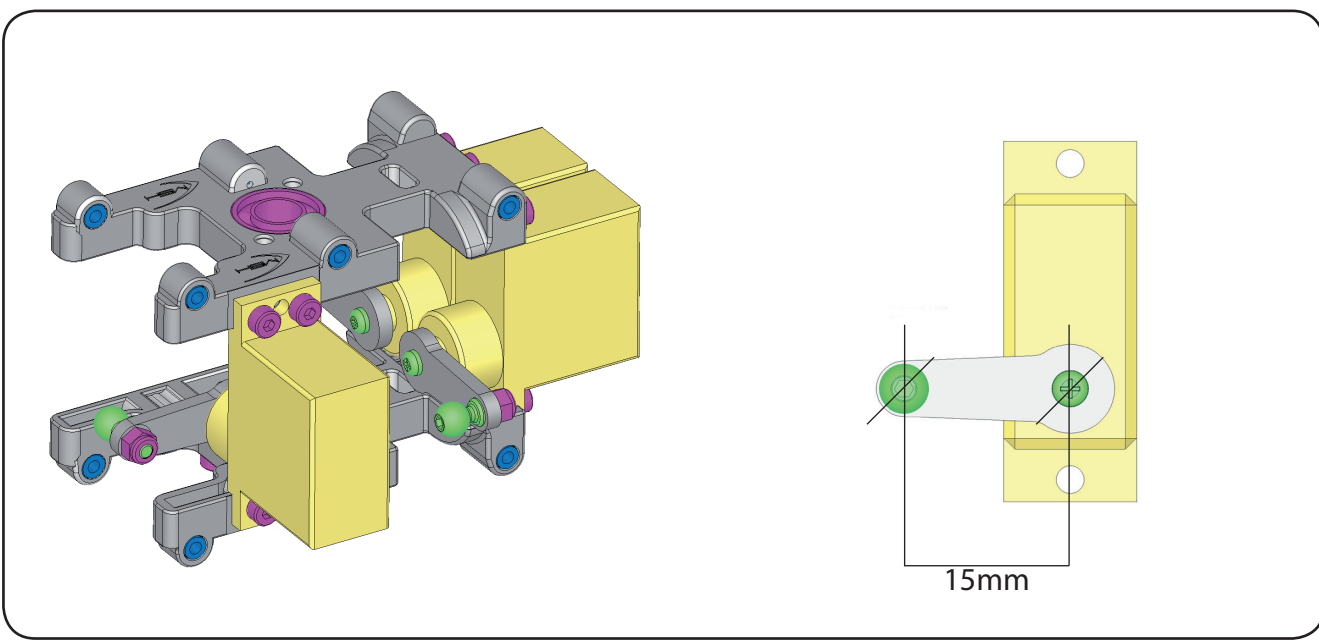
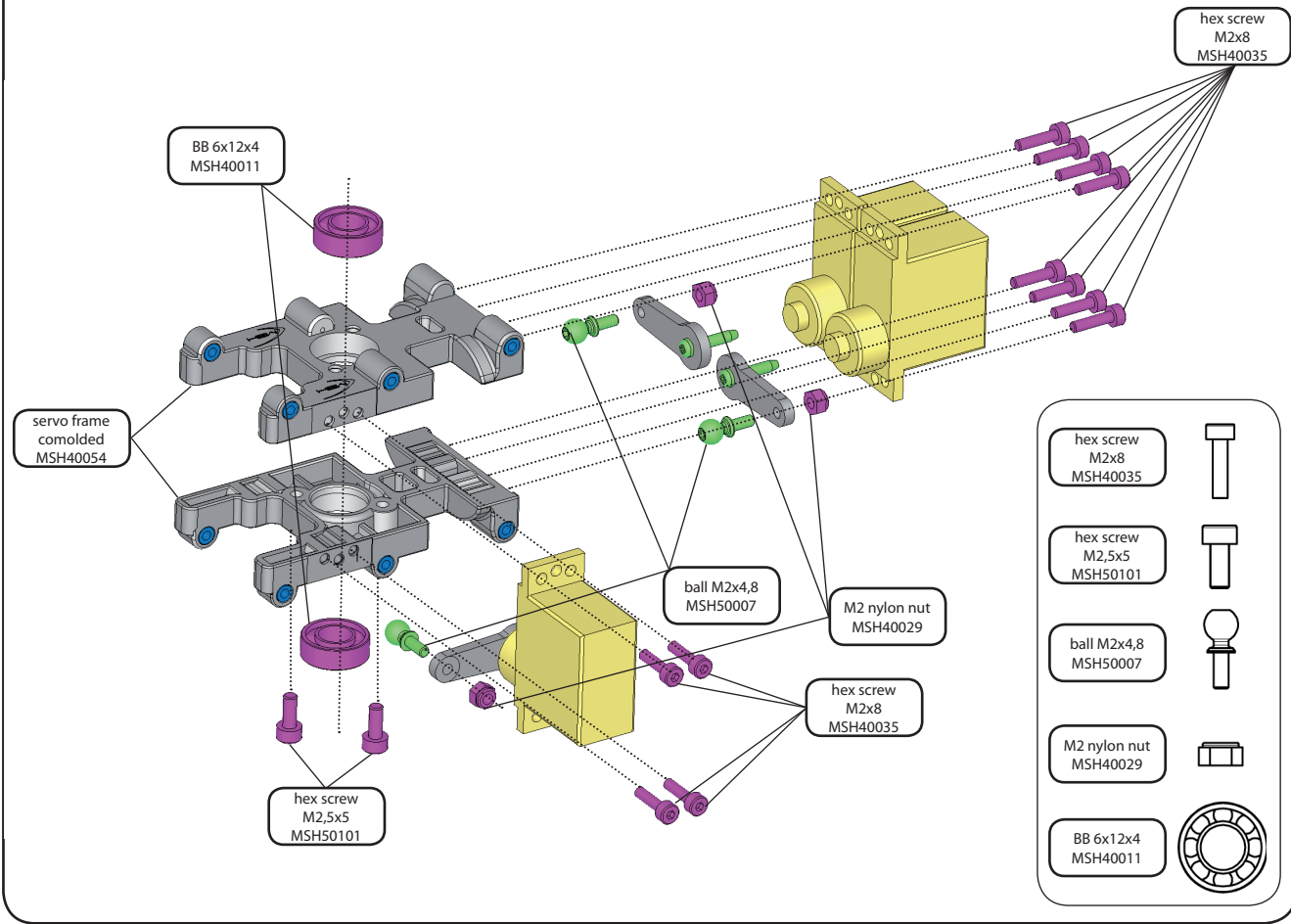

BAG B

pin
2,5x12



BB 2,5x7x2,5
MSH40004

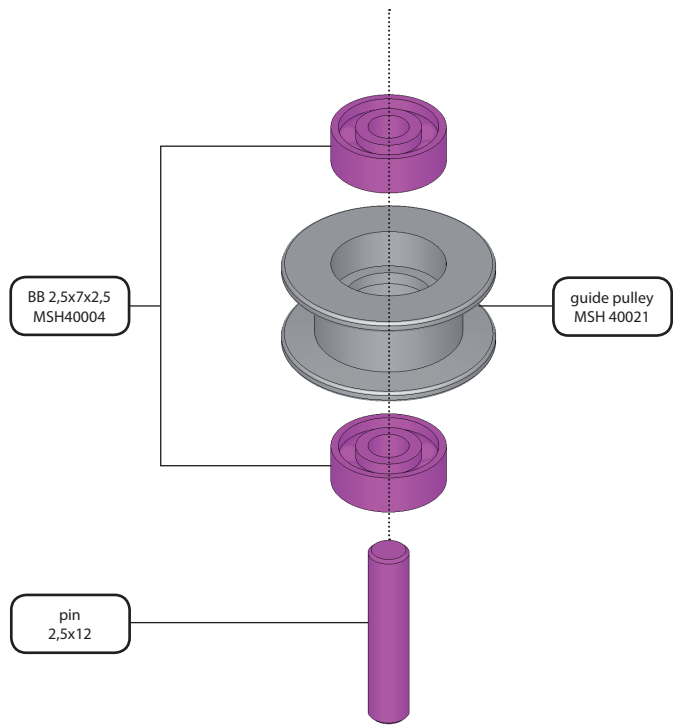

CLICK IN POSITION

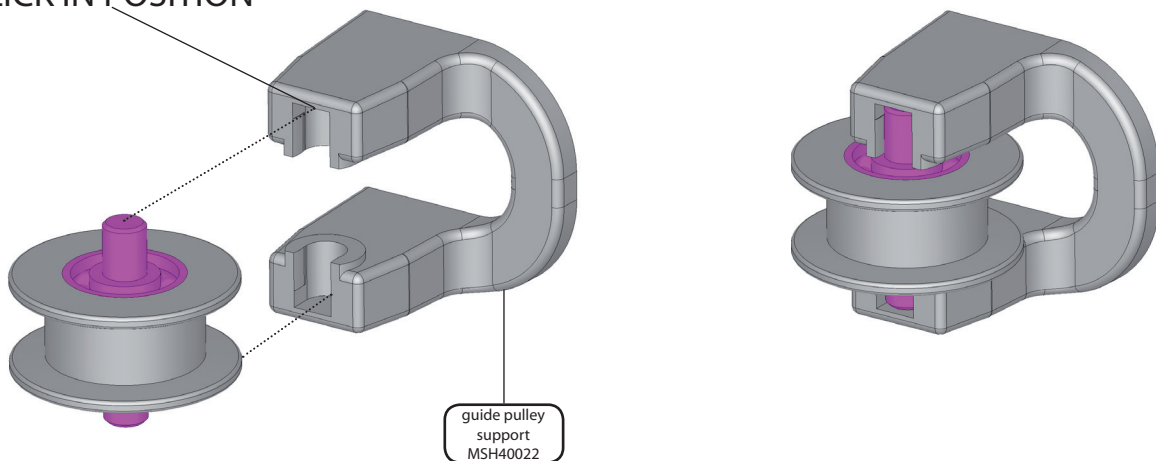

BAG B

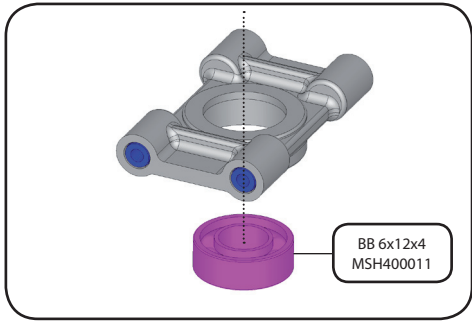

- hex screw
M2x6
MSH50098
- hex screw
M2x8
MSH40035
- washer
2,1x5,5x1
MSH40085
- BB 6x12x4
MSH40011

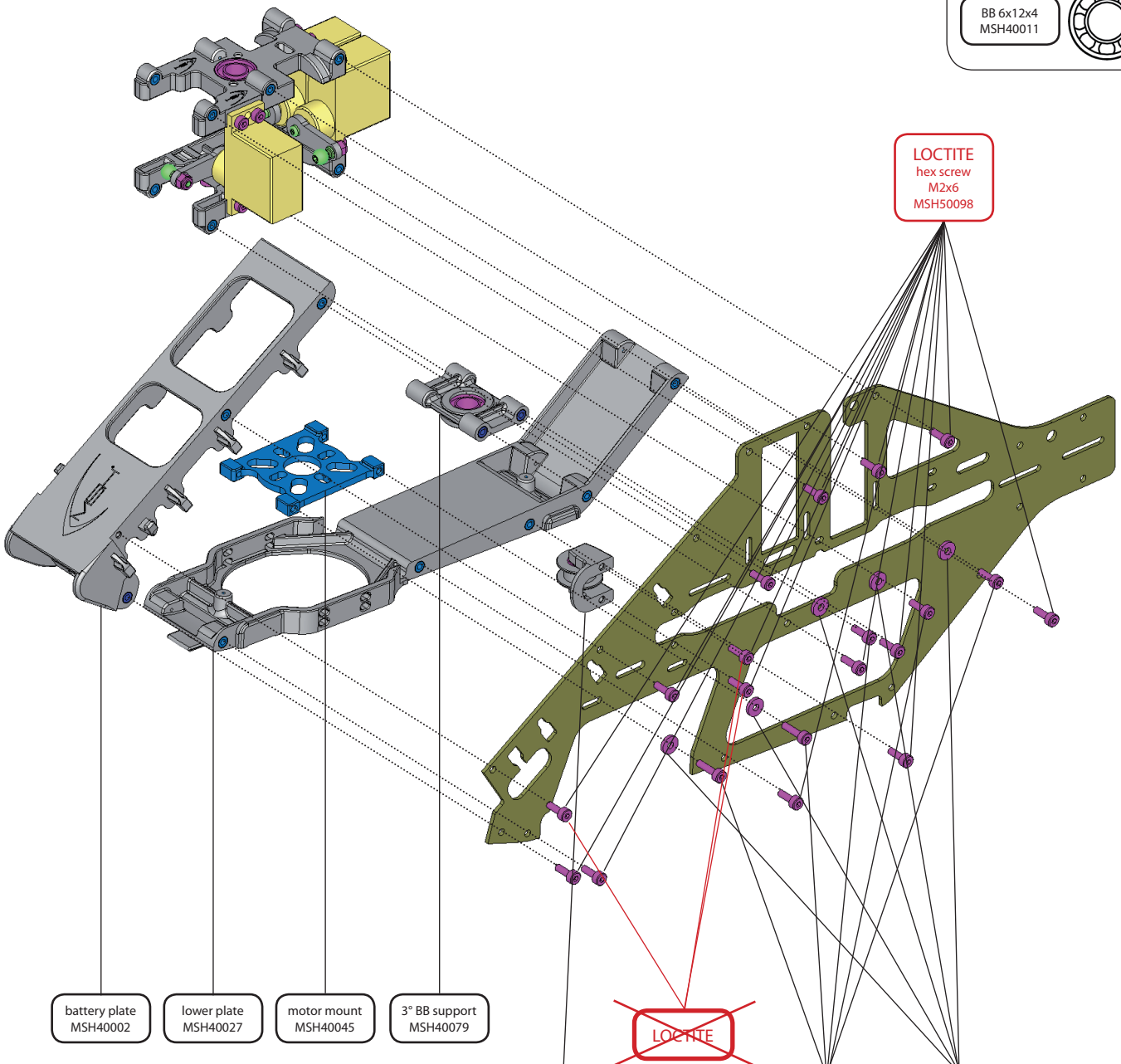

- battery plate
MSH40002
- lower plate
MSH40027
- motor mount
MSH40045
- 3° BB support
MSH40079

guide pulley support
MSH40022

~~LOCTITE~~

LOCTITE
hex screw
M2x8
MSH40035

washer
2,1x5,5x1
MSH40085

LOCTITE
hex screw
M2x6
MSH50098

BAG B

hex screw
M2x6
MSH50098



hex screw
M2x8
MSH40035



washer
2,1x5,5x1
MSH40085

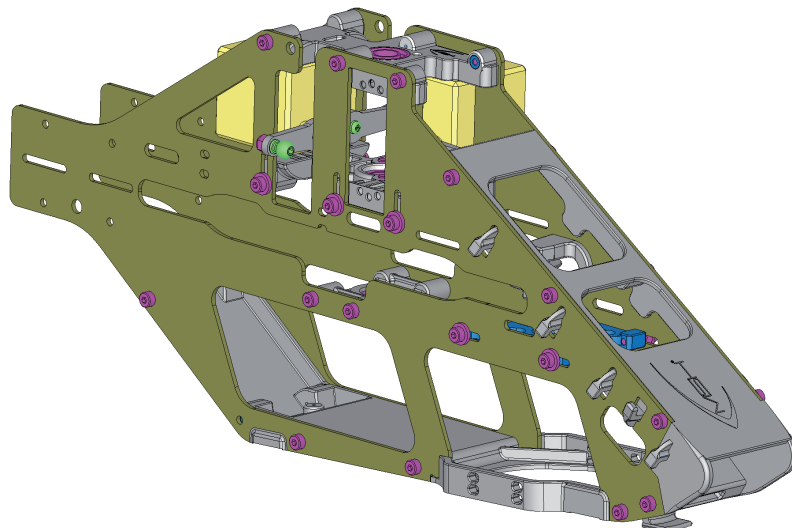
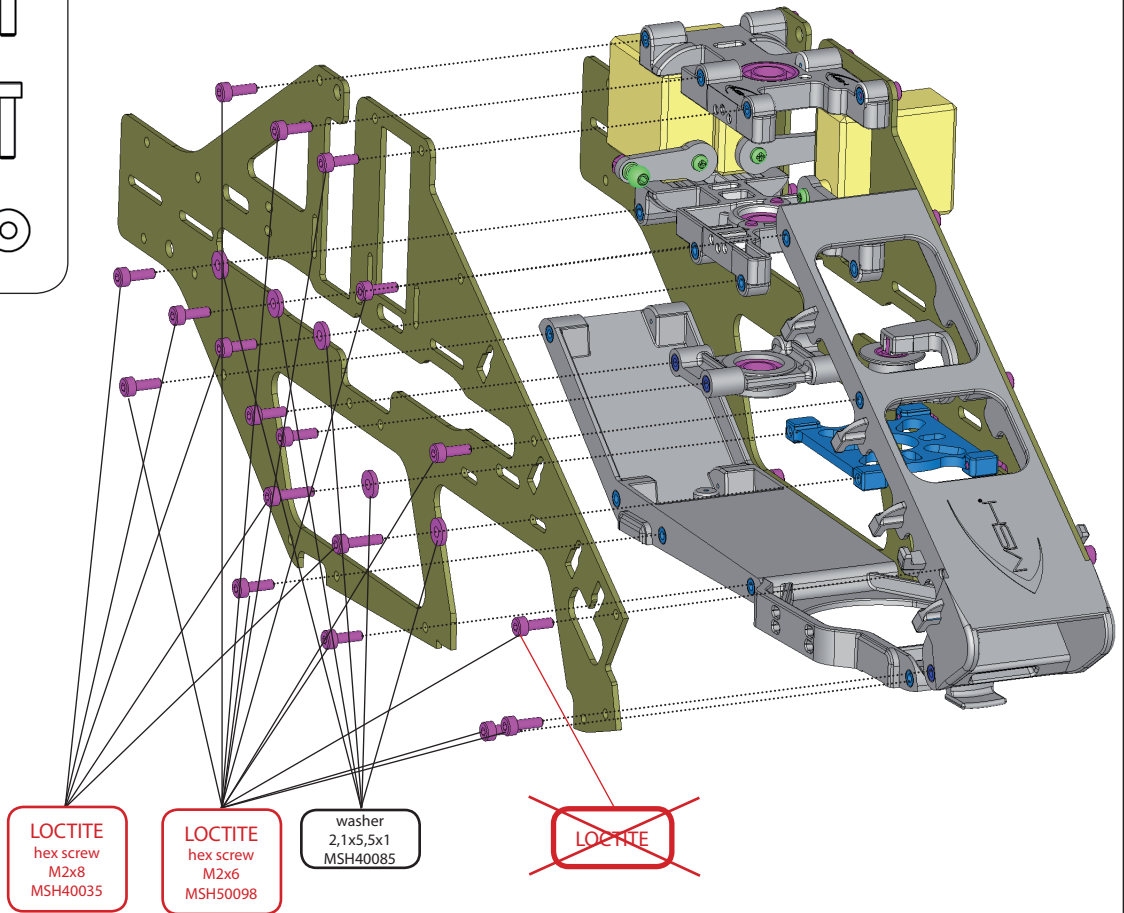

BAG B

- hex screw
M2x10
MSH50099
- hex screw
M2x8
MSH40035

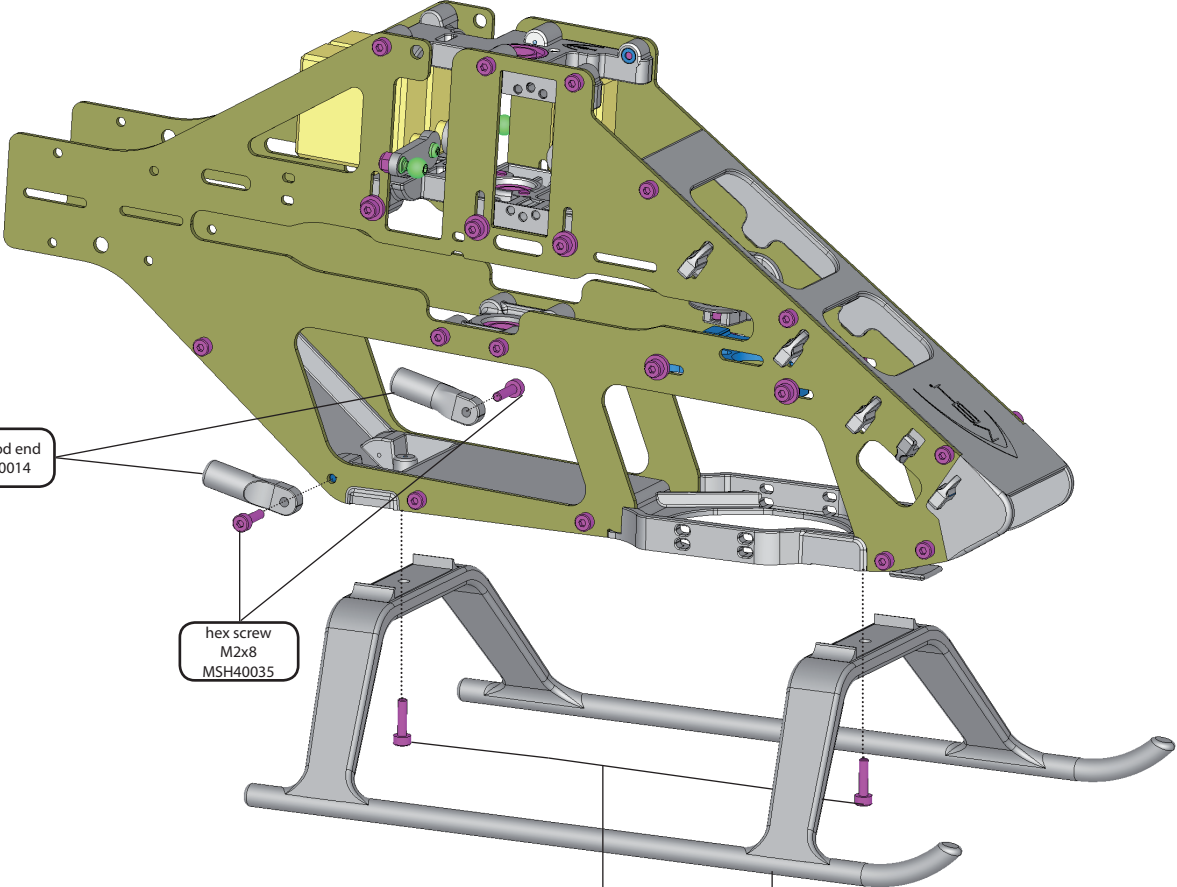

do not tighten
brace rod ends screws yet

LOCTITE
hex screw
M2x10
MSH50099

landing gear
MSH50311

BAG B

hex grub screw
M3x12
MSH40030

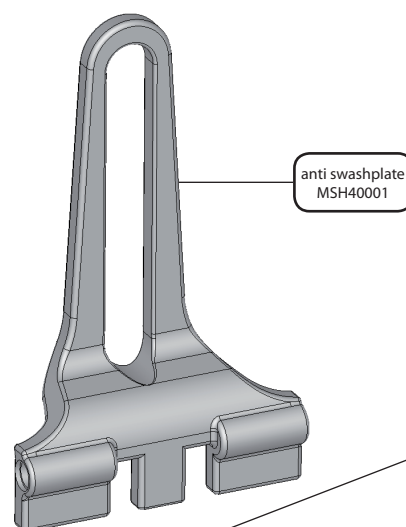
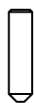

hex grub screw
M3x12
MSH40030

canopy stand
MSH40016

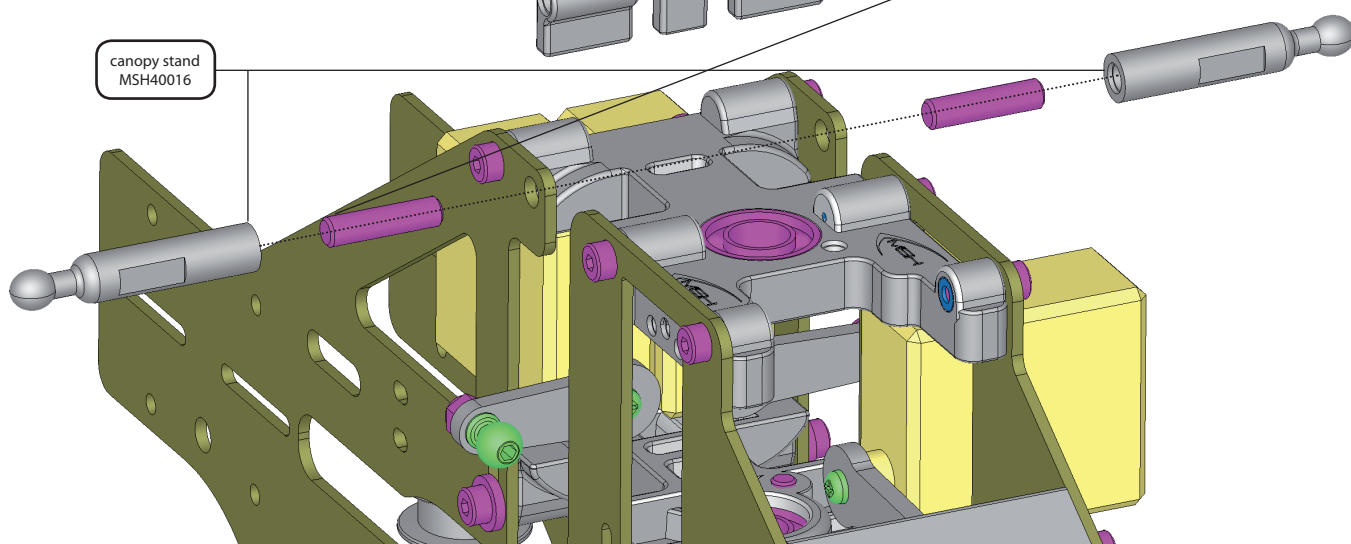

tighten antiswashplate spin
with hex grubscrew M3x12
BEFORE mounting canopy stands

BAG C

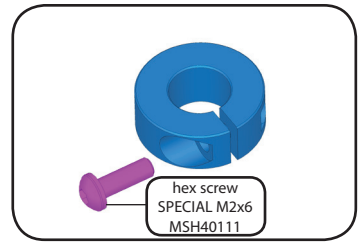

- hex screw M2x14 MSH40031
- nylon nut M2 MSH40029
- hex screw SPECIAL M2x6 MSH40111
- hex screw SPECIAL M2x6 MSH40111
- washer 2,6x6,5x1,5 MSH50146

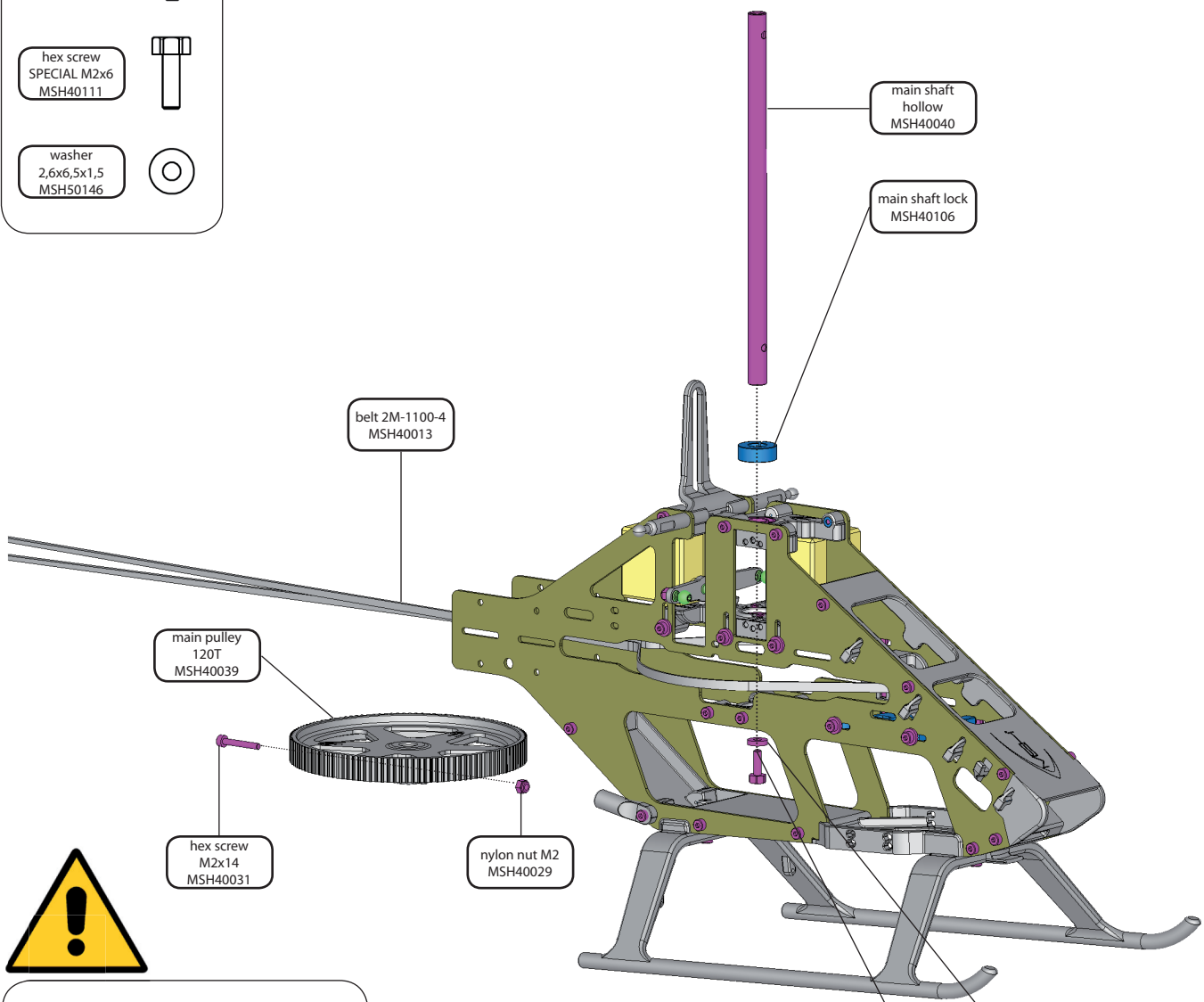

when tightening shaft collar check that there is no vertical play in main shaft assembly.

before sliding main shaft in position make sure belt is already in position

insert main shaft with M2,5 threaded hole facing down

BAG C

swashplate flybarred

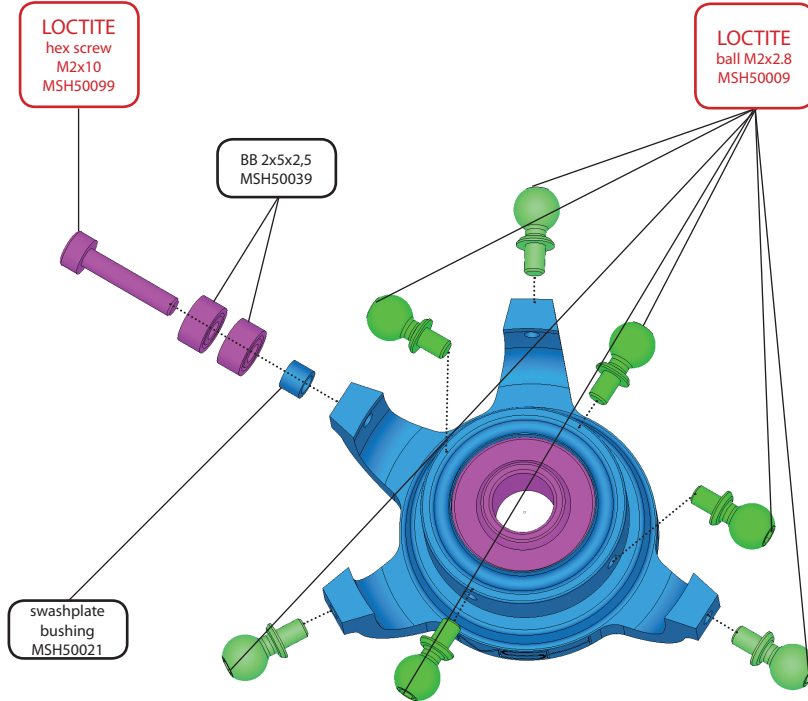

- hex screw M2x10 MSH50099
- nylon nut M2 MSH40029
- ball M2x2,8 MSH5009
- BB 2x5x2,5 MSH50039
- ball M2x2,8 MSH5009

BAG C

swashplate flybarless

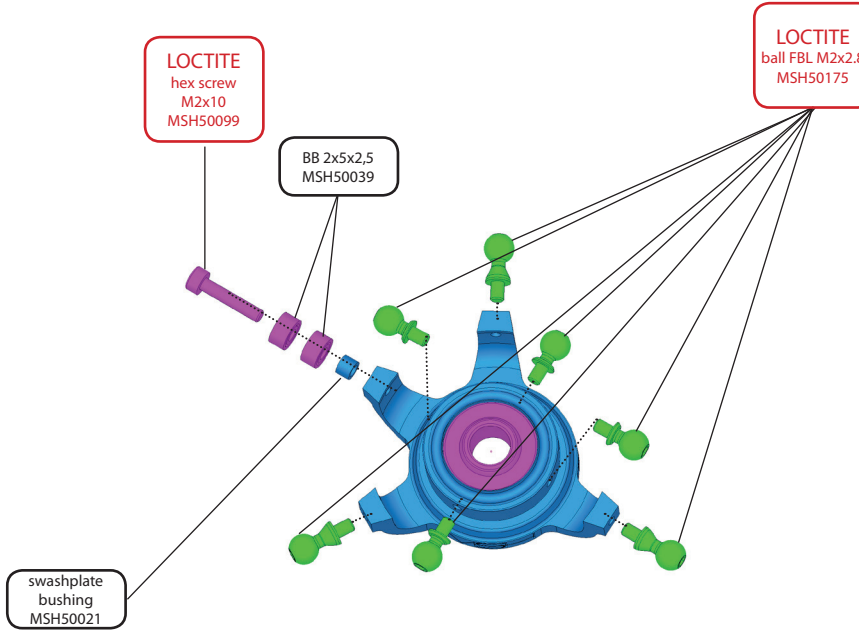

- hex screw M2x10 MSH50099
- nylon nut M2 MSH40029
- ball FBL M2x2,8 MSH50175
- BB 2x5x2,5 MSH50039
- swashplate bushing MSH50021

BAG C

uniball hand L
MSH50092



rod E 35mm
MSH50045

uniball hand L
MSH50092

uniball hand L
MSH50092

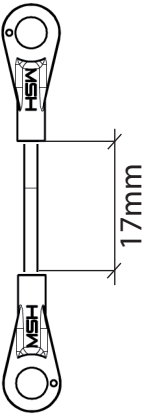

check for links smoothness
if tight use provided reamer

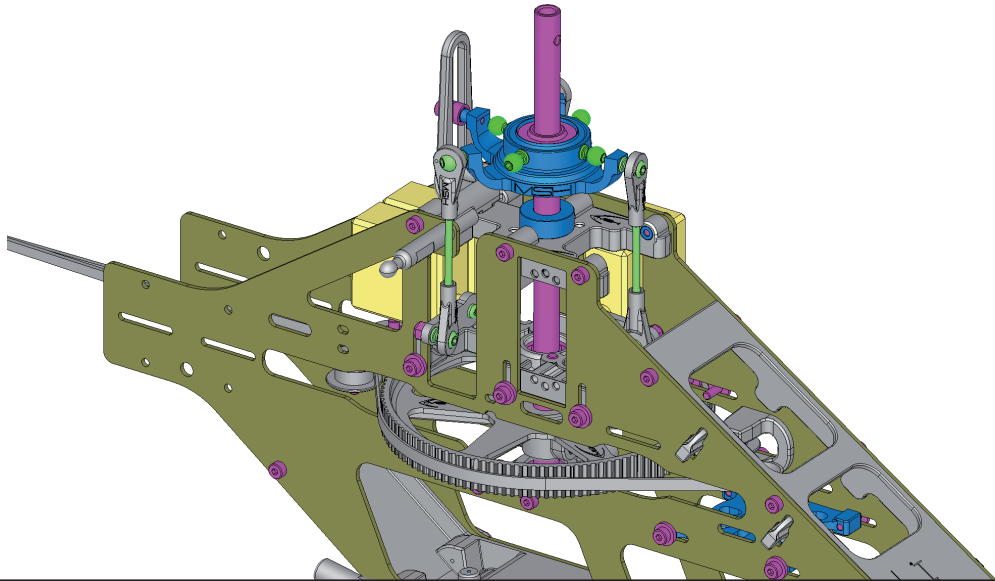
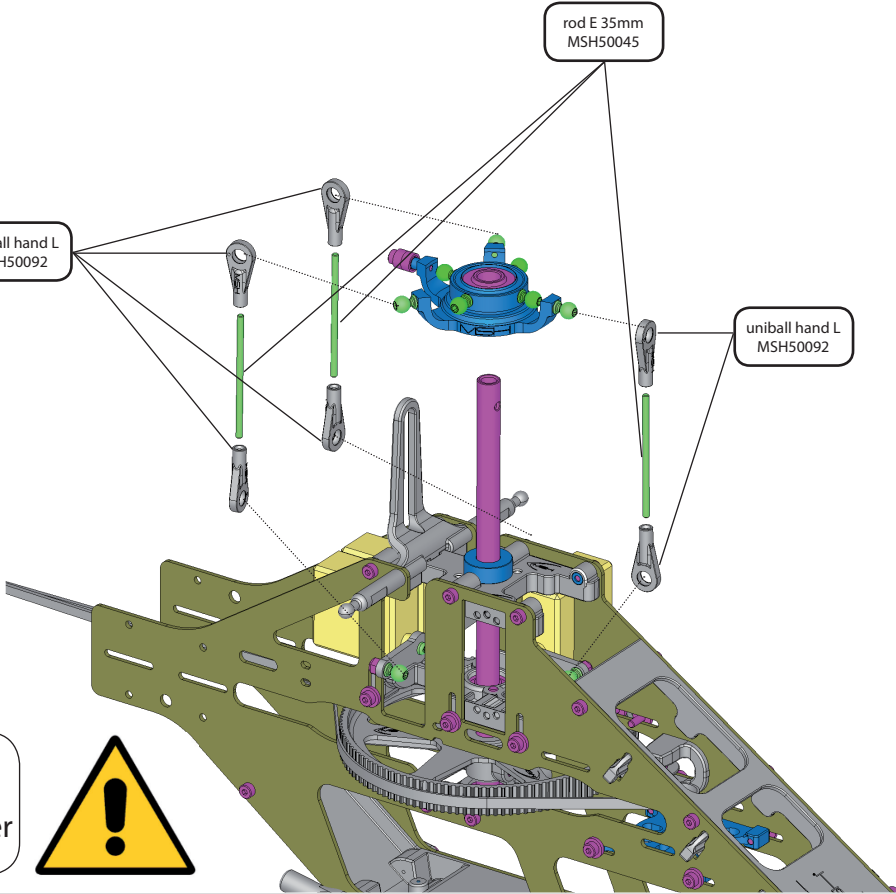

rotor head flybarred

for flybarless rotorhead jump to page 24



BAG D

hex screw
M2x10
MSH5099



ball M2x4,8
MSH50007



bb spacer
MSH40012



BB 2x5x2,5
MSH50039



pin 2x12 M6
MSH50058



check carefully that
BB spacer is in position
between BB before
tightening assembly

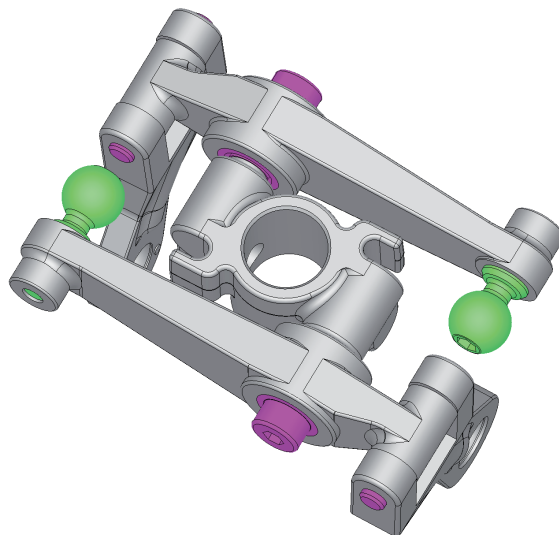
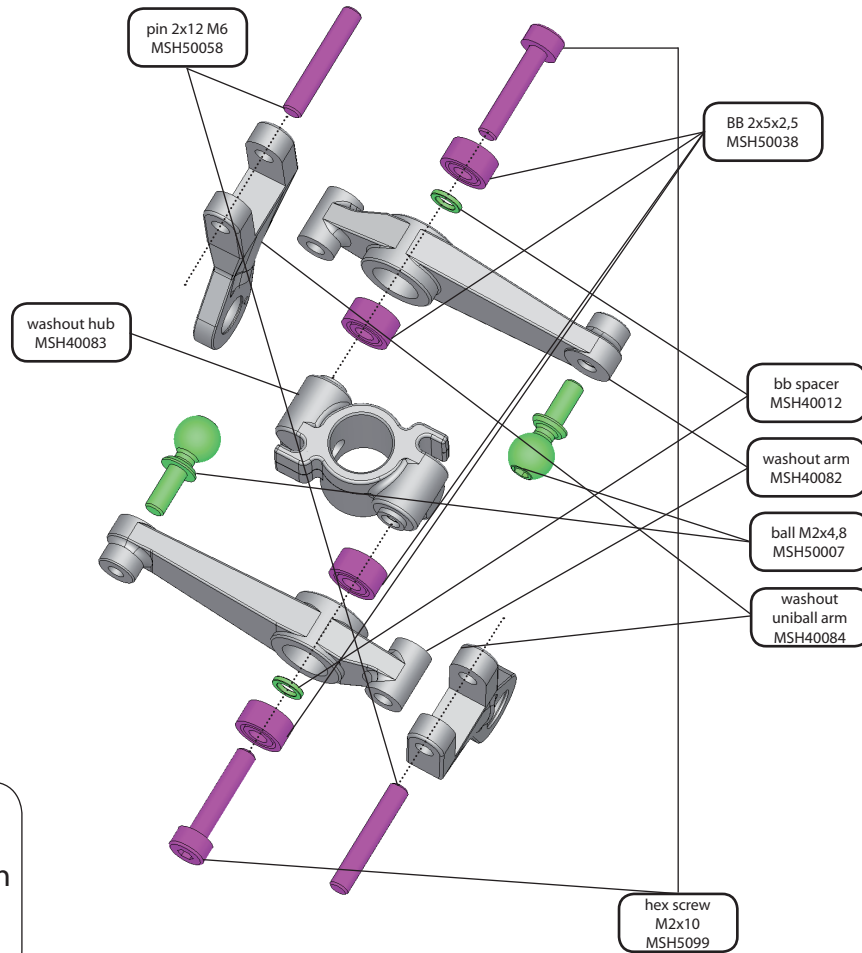

BAG D

hex screw
M2x6
MSH50098



BB 2x5x2,5
flanged
MSH50041



BB 2x5x2,5
MSH50039

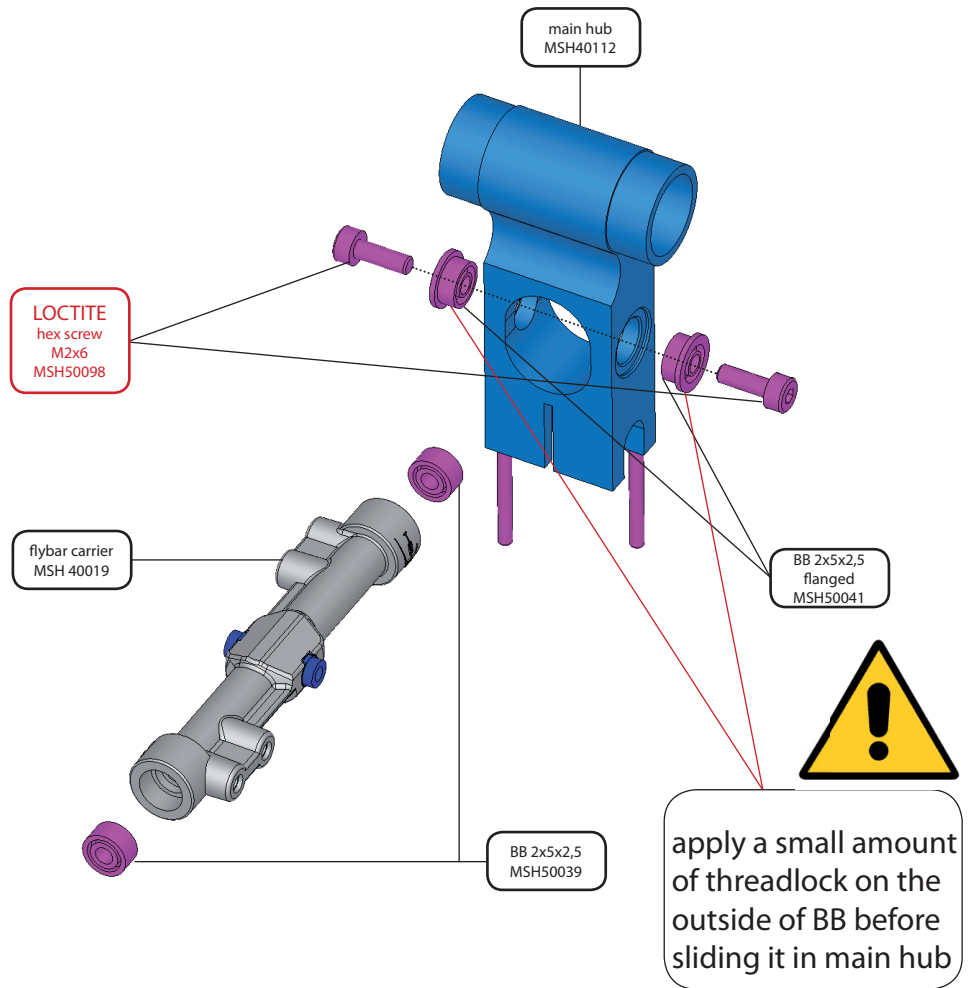

ball M2x4,8
MSH50007

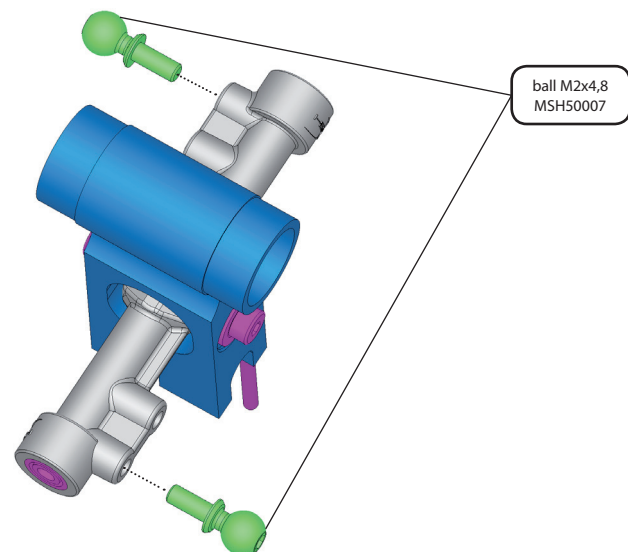

BAG D

hex screw
M2x6
MSH50098



hex grub
screw
M3x3 MSH50117



uniball hand S
MSH50096

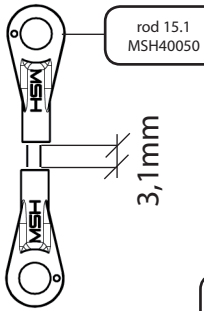
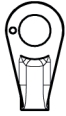

rod 15,1mm
MSH40050

flybar rod
MSH40020

uniball hand S
MSH50096

LOCTITE
hex screw
M2x6
MSH50098

flybar arm
MSH40018

LOCTITE
hex grub screw
M3x3
MSH50117

cross ball
MSH40017



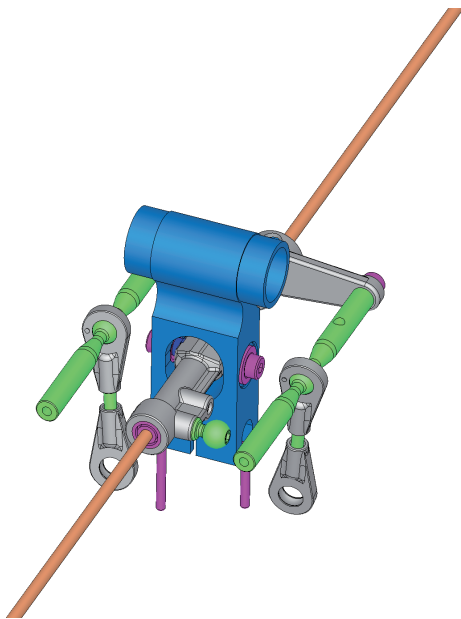

check for links smoothness
if tight use provided reamer



BAG D

- 

hex screw
M2x6
MSH50098
- 

hex grub screw
M3x3 MSH50117
- 

uniball hand S
MSH50096



before tightening M3x3 grub screw check for crossball alignment

paddle weight
2,5x50
MSH50062

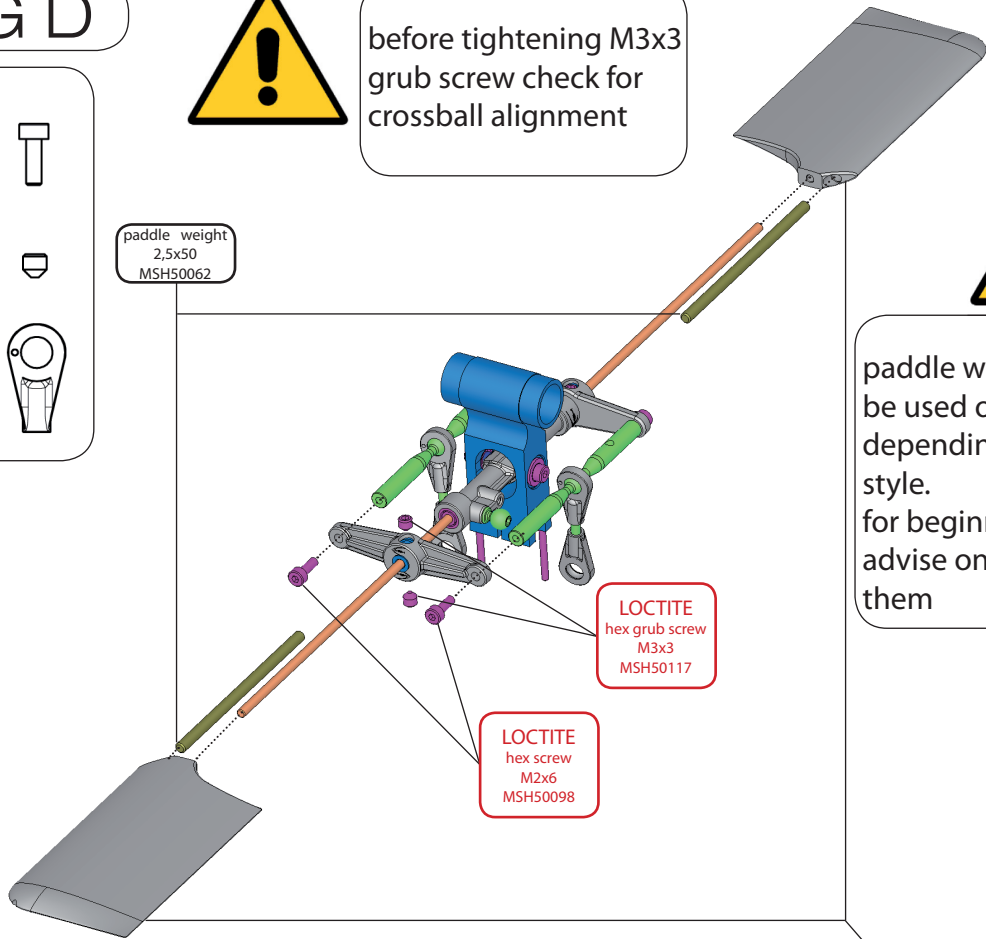

paddle weights can be used or not depending on flying style. for beginners we advise on using them

LOCTITE
hex grub screw
M3x3
MSH50117

LOCTITE
hex screw
M2x6
MSH50098

paddle
MSH50088

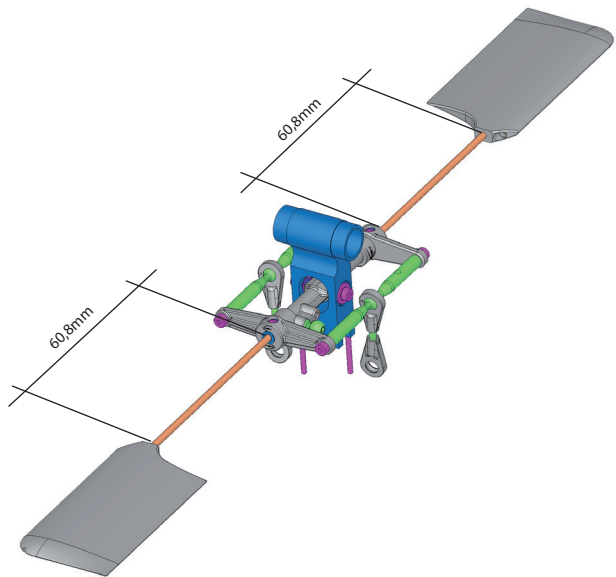

BAG D

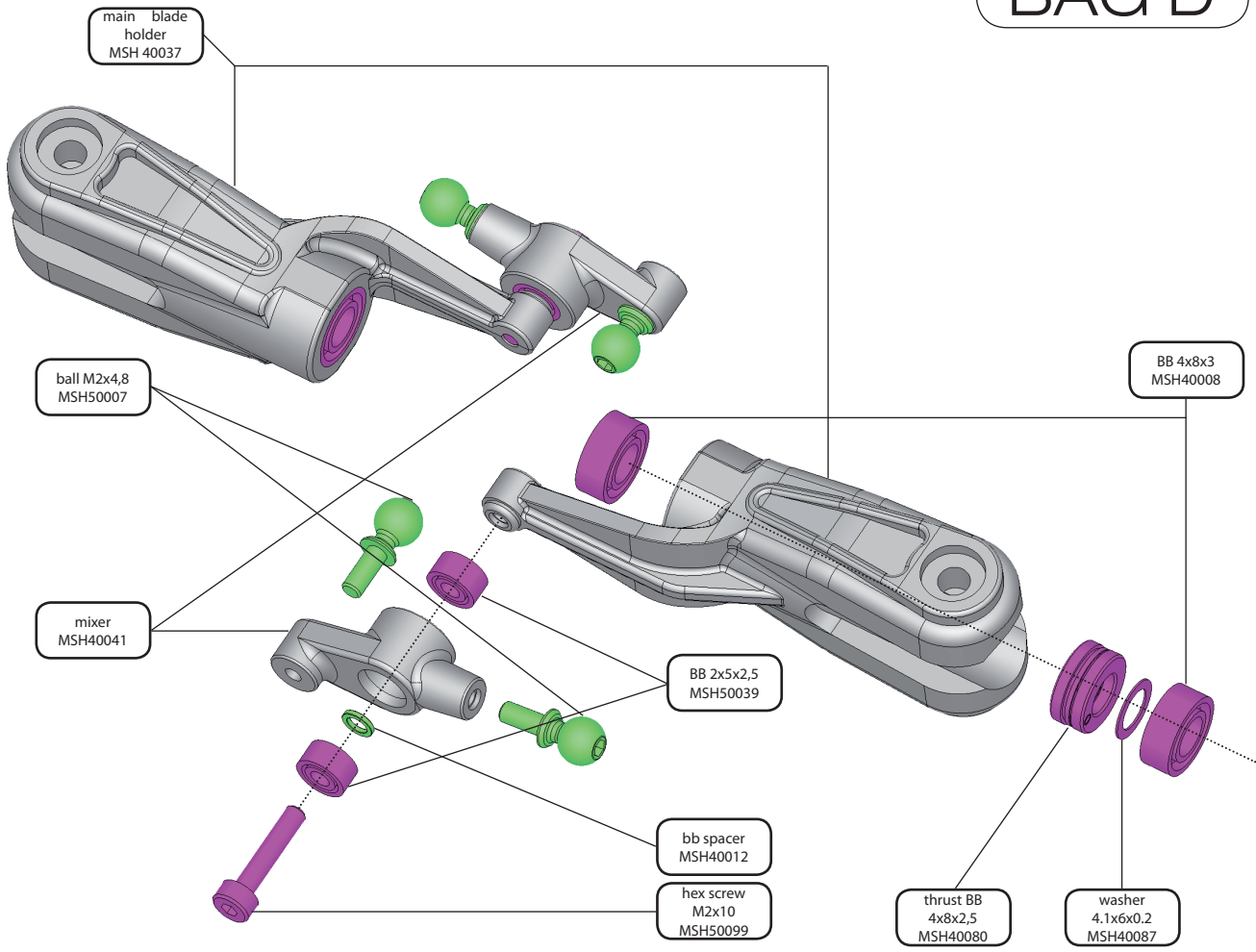

- thrust BB
4x8x2,5
MSH40080
- BB 4x8x3
MSH40008
- ball M2x4,8
MSH50007
- BB 2x5x2,5
MSH50039
- washer
4.1x6x0.2
MSH40087
- hex screw
M2x10
MSH50099
- bb spacer
MSH40012

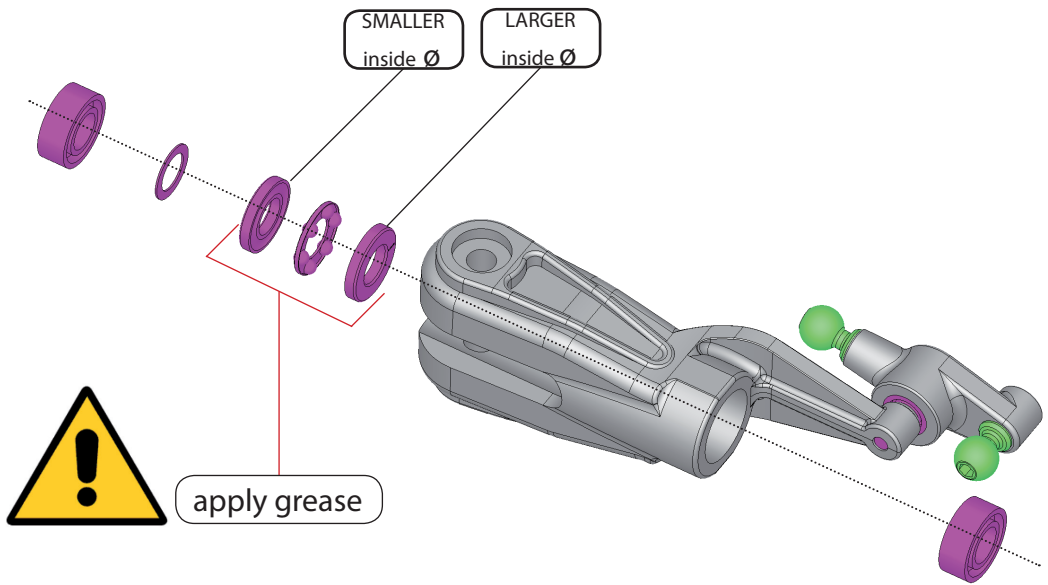

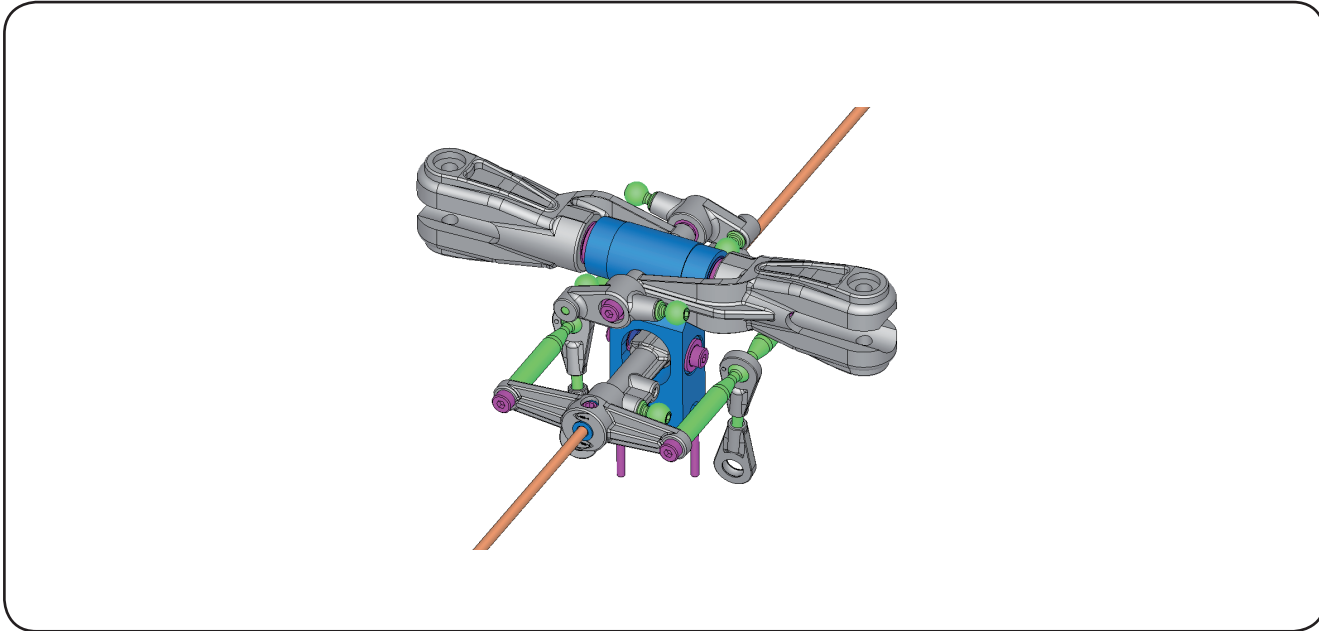
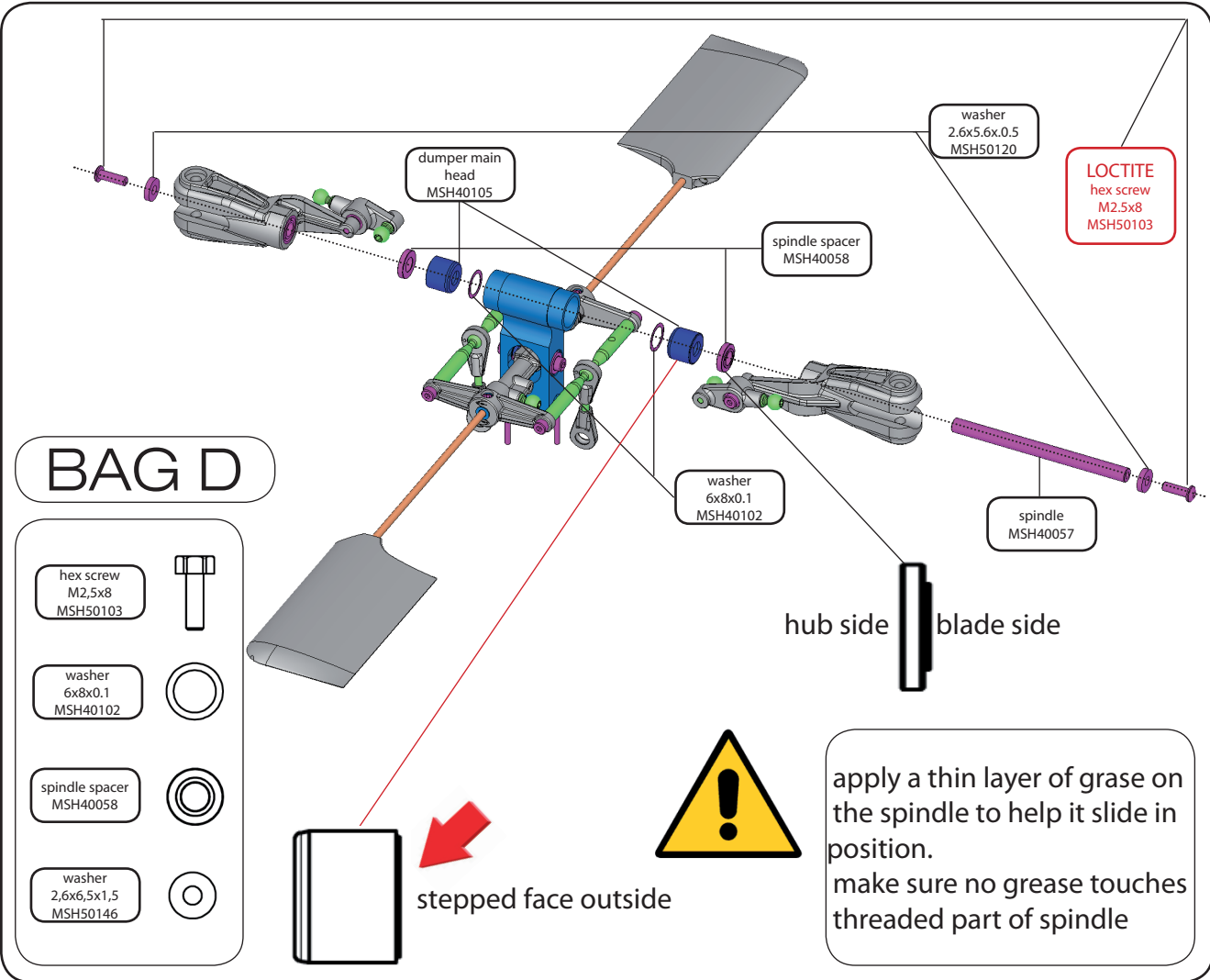

BAG D

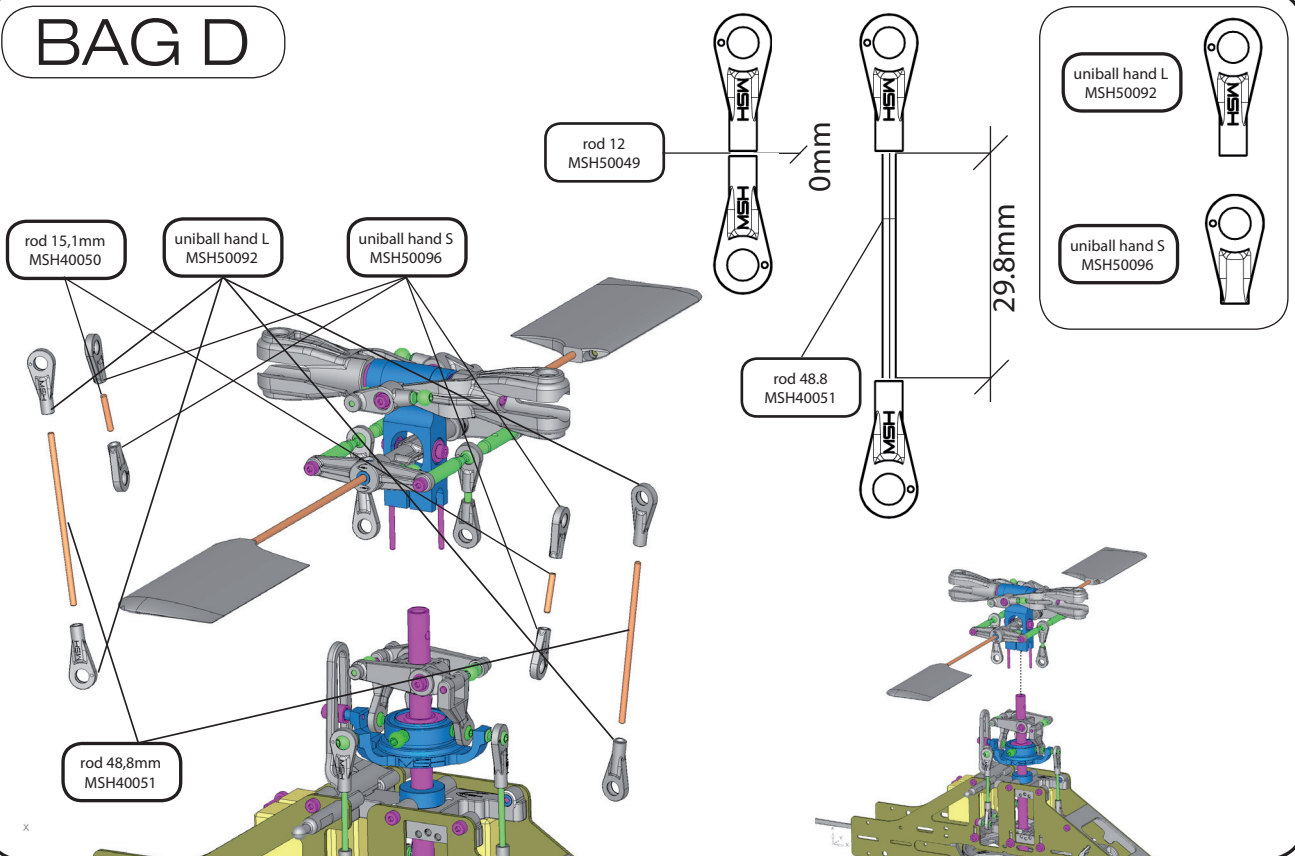

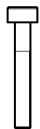
- 

hex screw
M2x14
MSH 40031
- 

M2 nylon nut
MSH40029

check for links smoothness
if tight use provided reamer

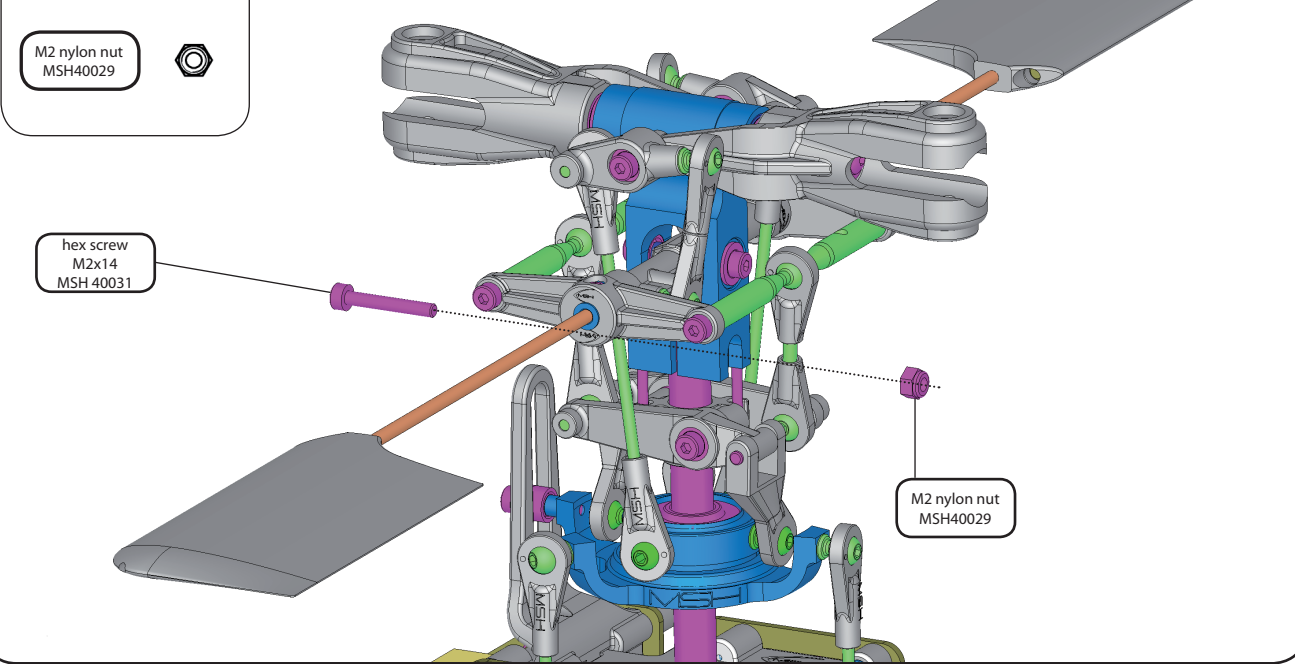

rotor head flybarless

for flybarred rotor head jump to page 16



BAG D

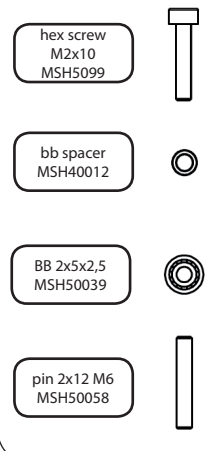
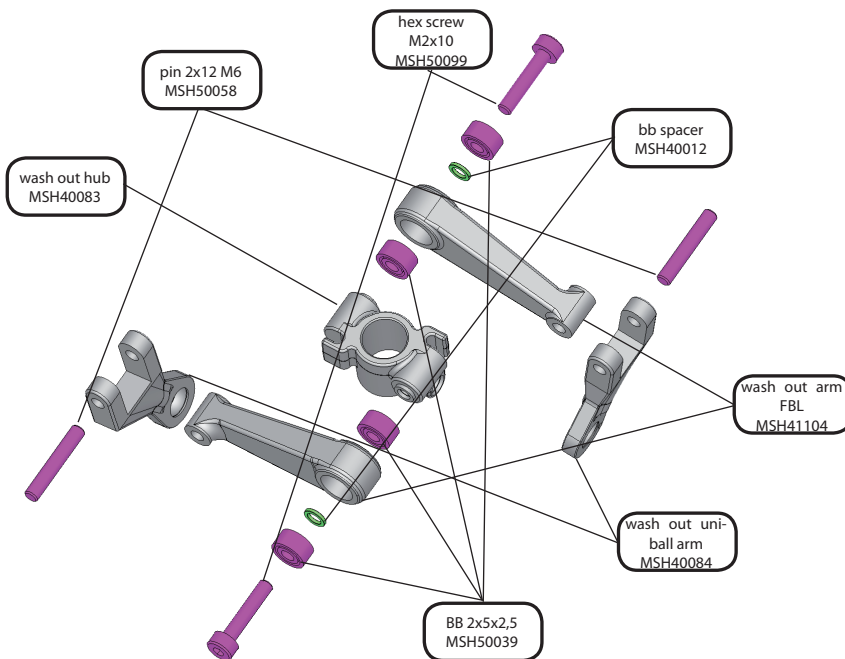

check for links smoothness
if tight use provided reamer



check carefully that
BB spacer is in position
between BB before
tightening assembly

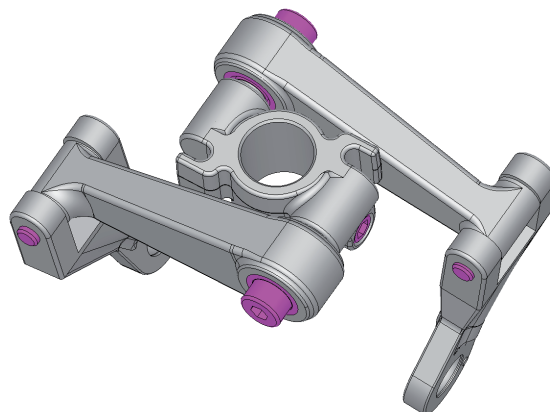

BAG D

ball long stand grips
MSH40107



spindle spacer FBL
MSH40109

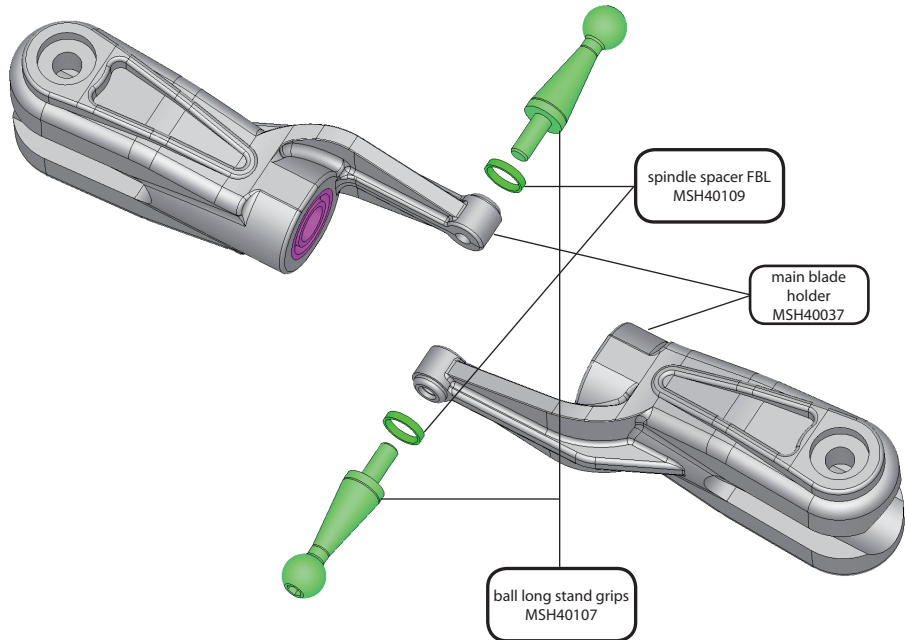

thrust BB
4x8x2,5
MSH40080



washer
4.1x6x0.2
MSH40087



BB 4x8x3
MSH40008

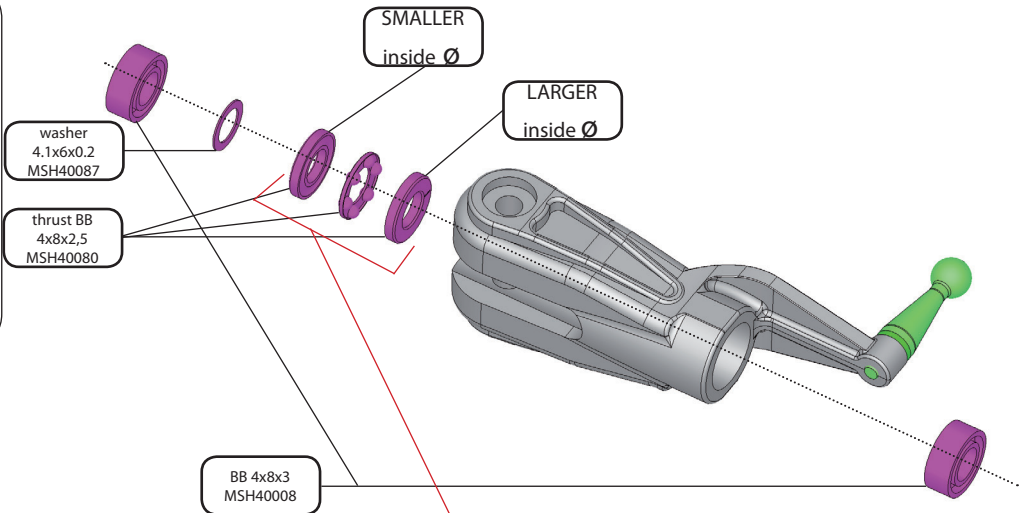

apply grease

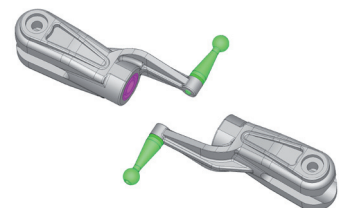

BAG D

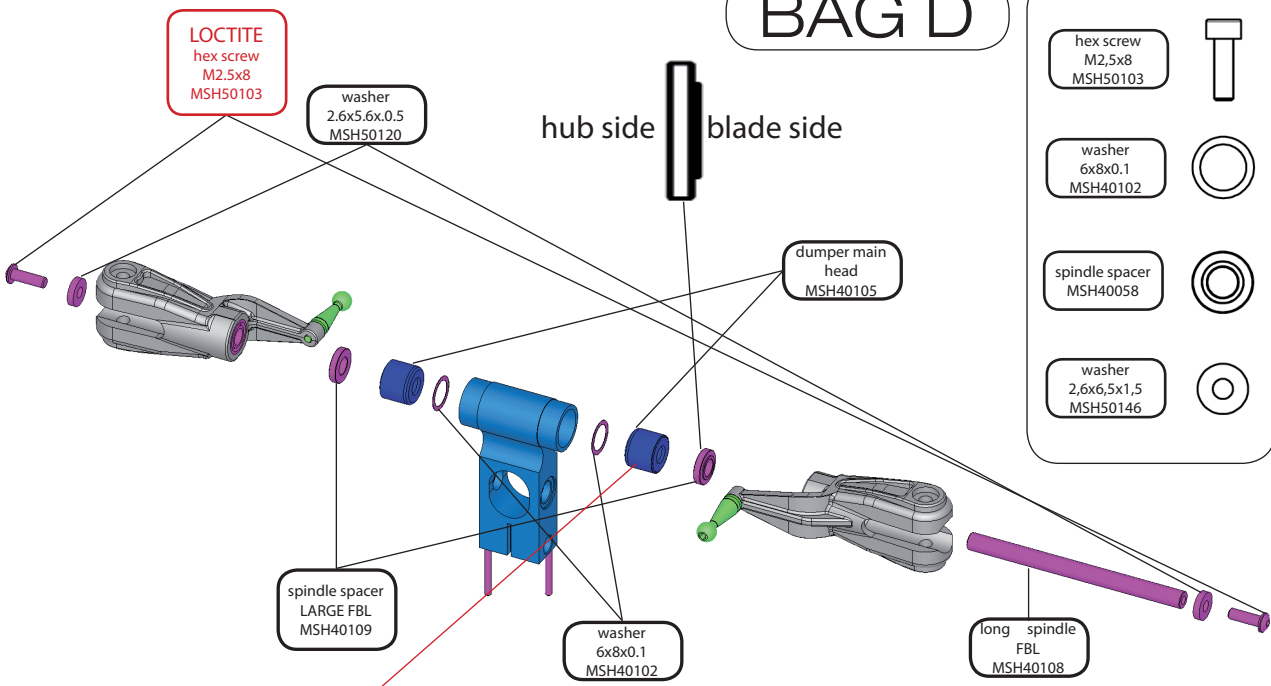

stepped face outside



Spindle spacer is a stepped washer, please make sure that, the stepped side faces BB 4x8x3.

apply a thin layer of grease on the spindle to help it sliding in position.
make sure no grease touches threaded part of spindle.

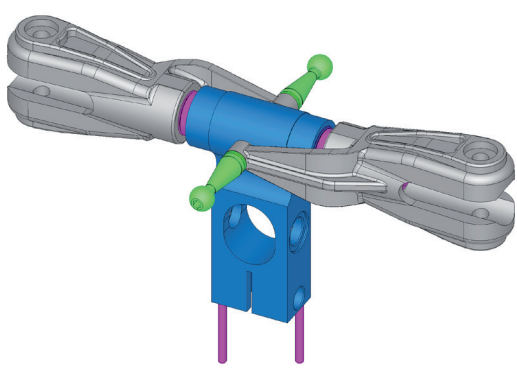

BAG D

M2 nylon nut
MSH40029



hex screw
M2x14
MSH 40031



hex screw grub M3x5
MSH50116

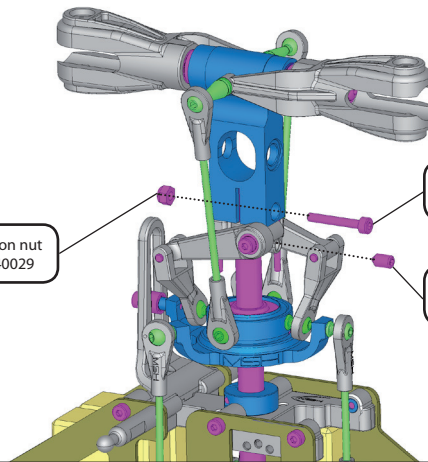
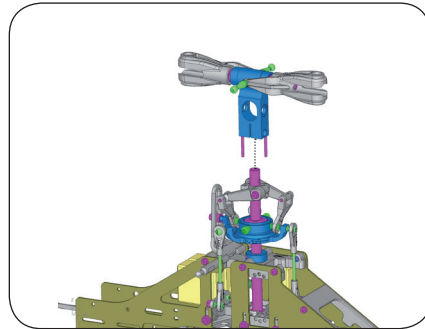

M2 nylon nut
MSH40029

hex screw
M2x14
MSH 40031

hex screw grub
M3x5
MSH50116

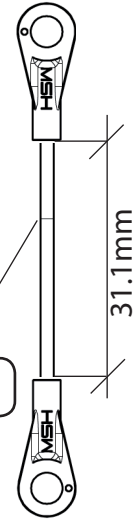

rod 48.8
MSH40051

31.1mm

uniball hand L
MSH50092



check for links smoothness
if tight use provided reamer



Slide washout hub all the way up against the main rotor head and secure it in position with provided hex grub screw M3x3.
Do not overtighten grub screw

BAG E

BB 2.5x7x2.5
MSH40004



pin
2,5x12 h6



BB 2.5x7x2.5
MSH40004

guide pulley
MSH40021

pin
2,5x12 h6

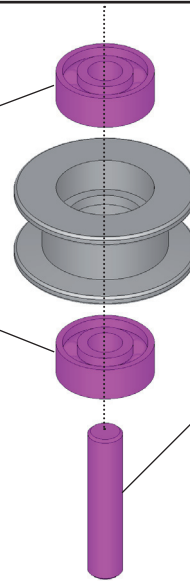

self tapping screw
2.2x9.5



tail boom
MSH40061

tail boom
clamp
MSH40063

self tapping
screw
2.2x9.5

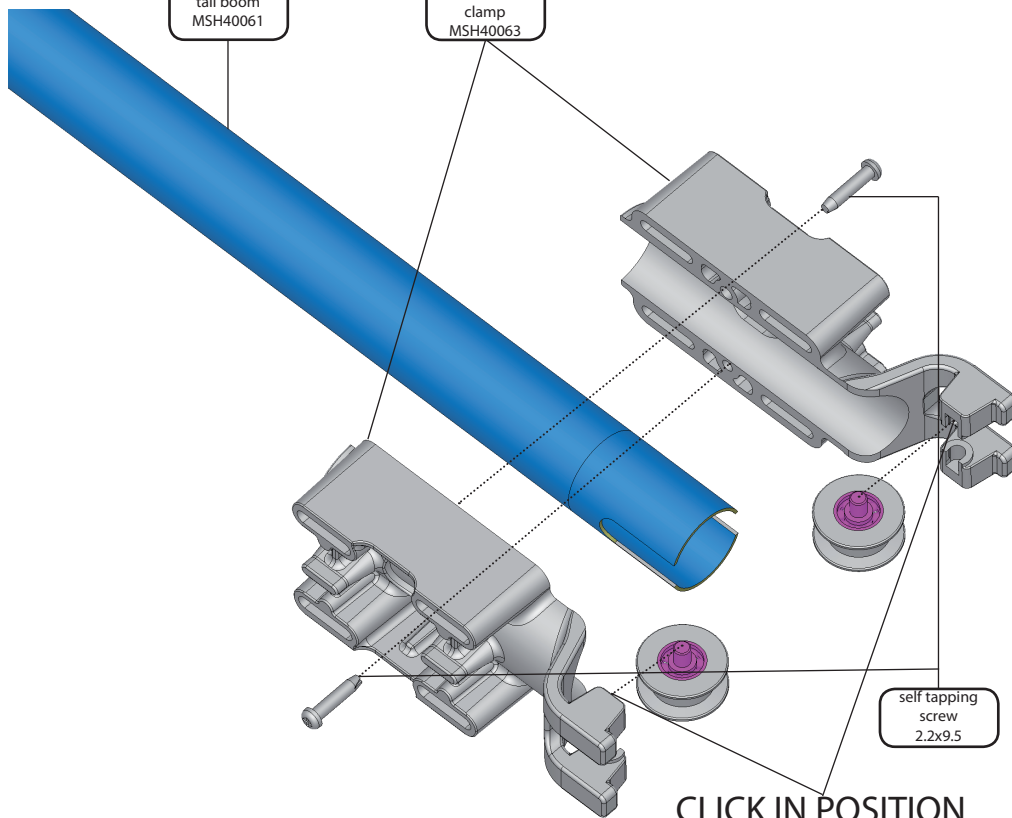



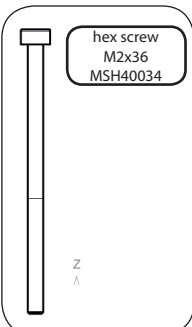
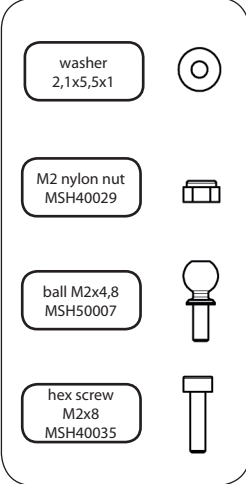
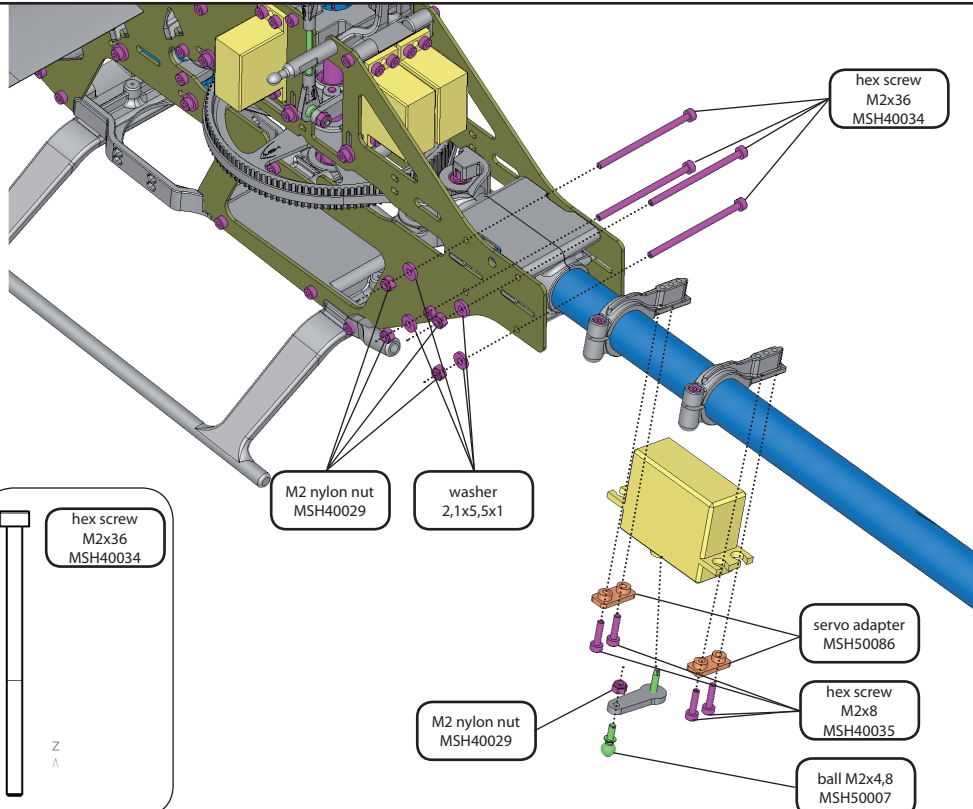
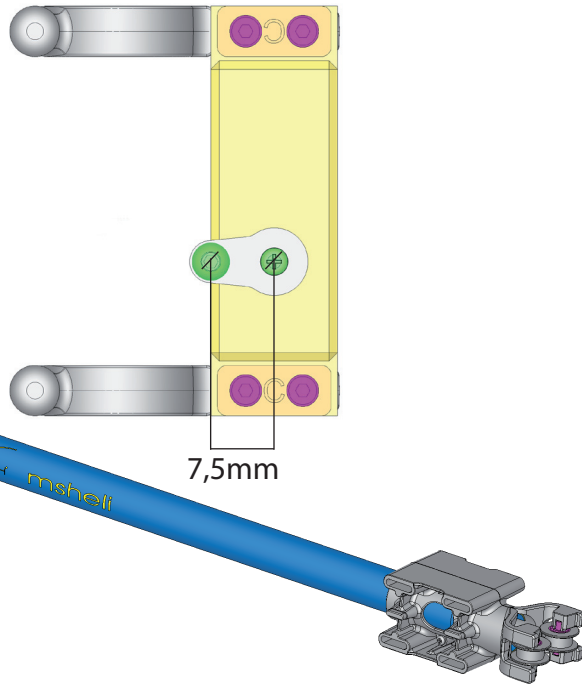
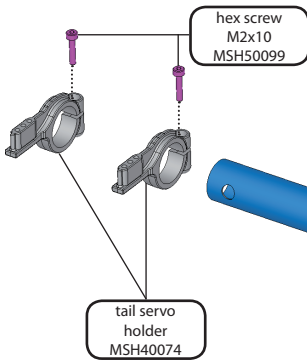

CLICK IN POSITION

BAG E

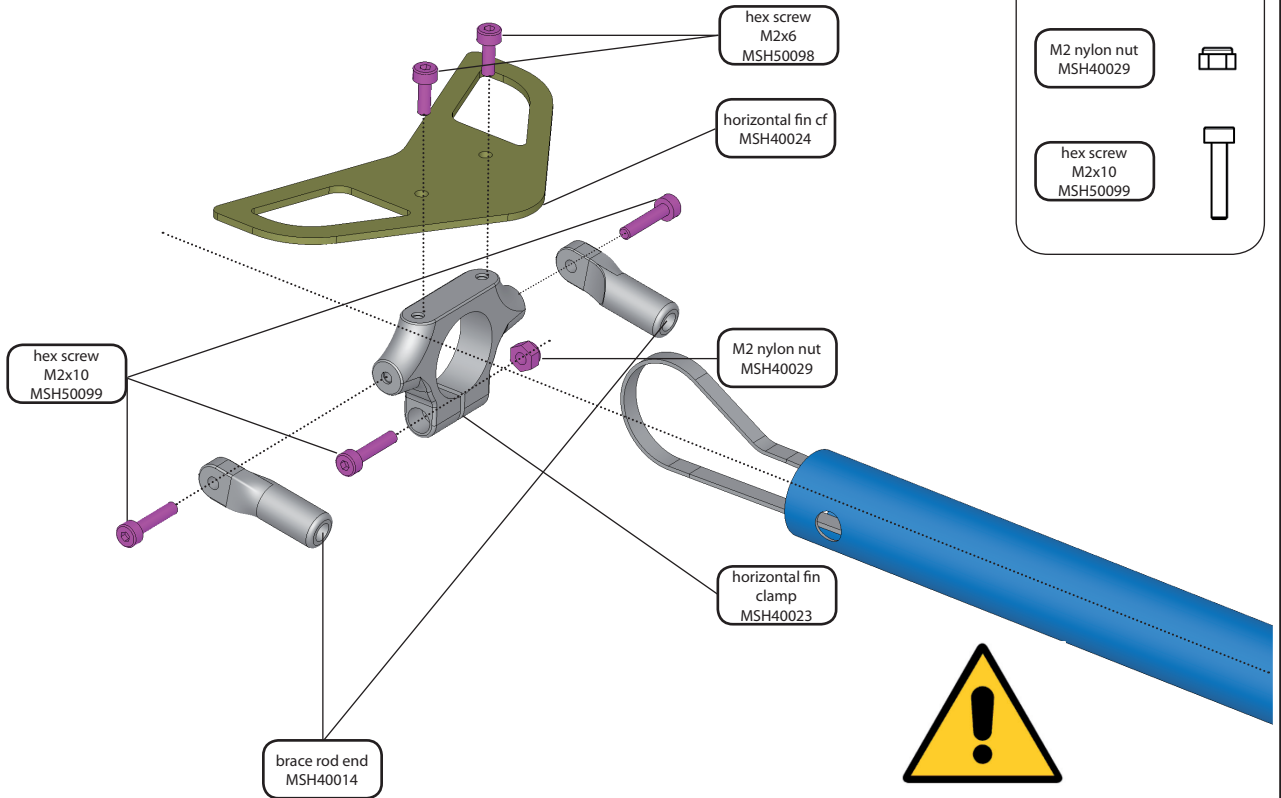

BAG G



- hex screw M2x6 MSH50098 
- M2 nylon nut MSH40029 
- hex screw M2x10 MSH50099 



do not tighten M2x10 brace rod ends screws yet

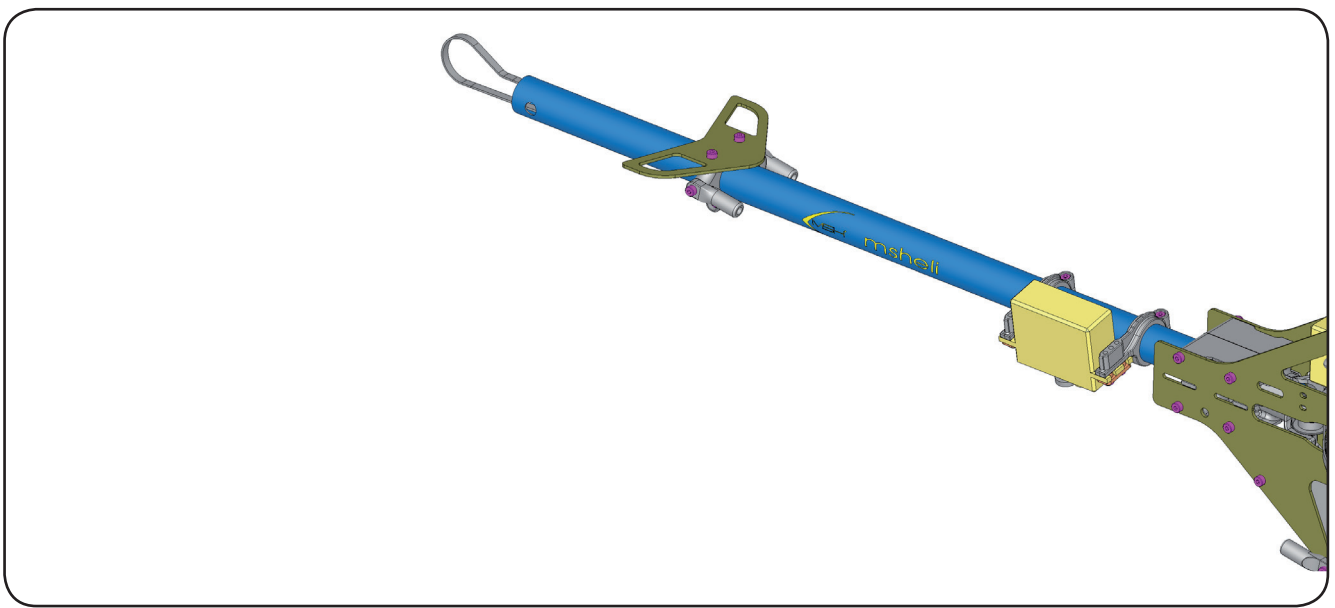

BAG F



make sure that tail shaft bushing is halfway inserted in tail pulley over the pin in picture

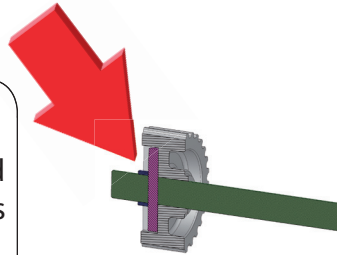

hex screw M2x20 MSH40033		M2 nylon nut MSH40029	
hex screw M2x14 MSH40031		pin 1,5x12 H6 MSH50144	
		tail shaft bushing MSH40076	
		BB 4x9x4 MSH40009	
		BB 4x7x2,5 MSH40007	

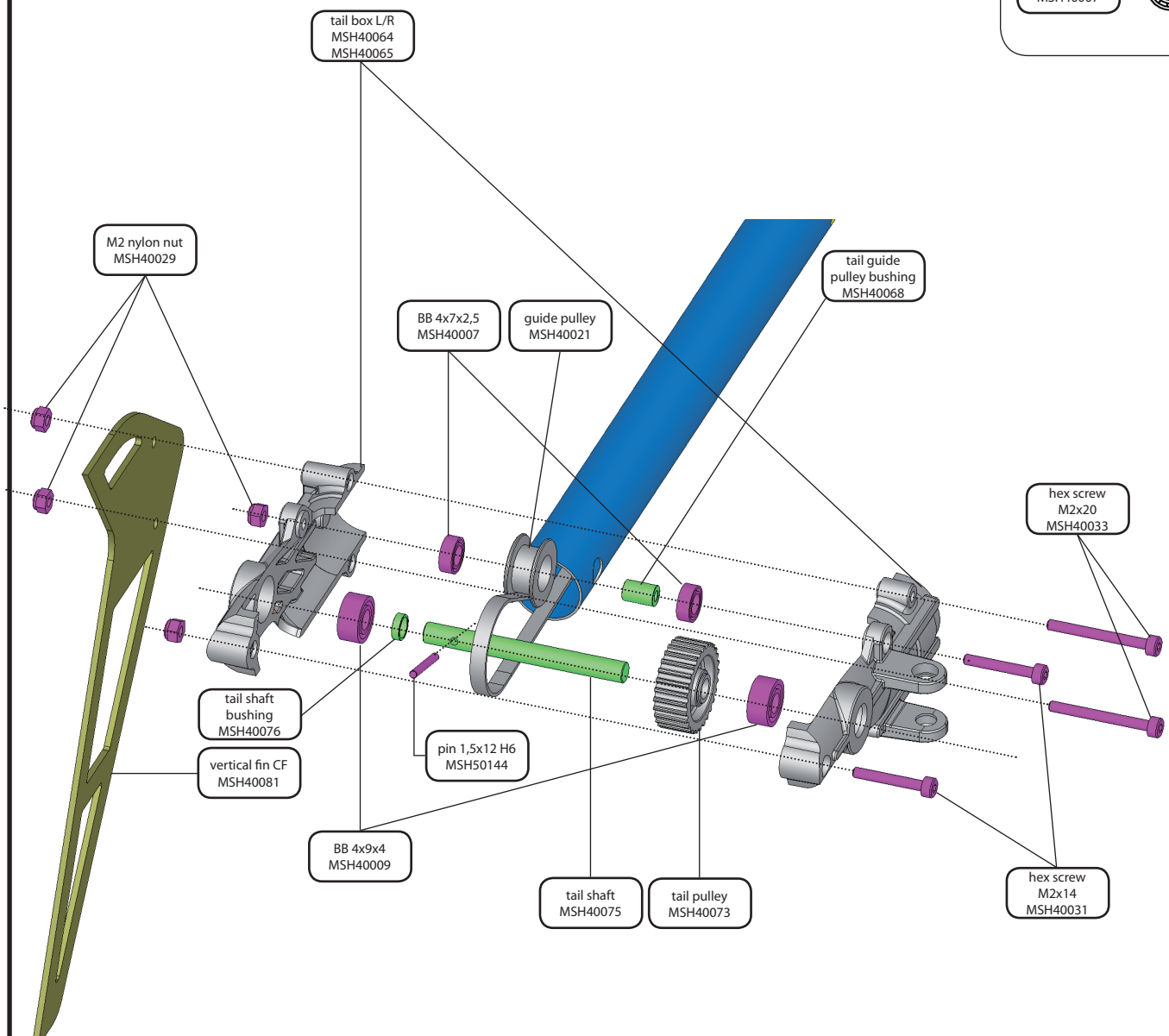

BAG F

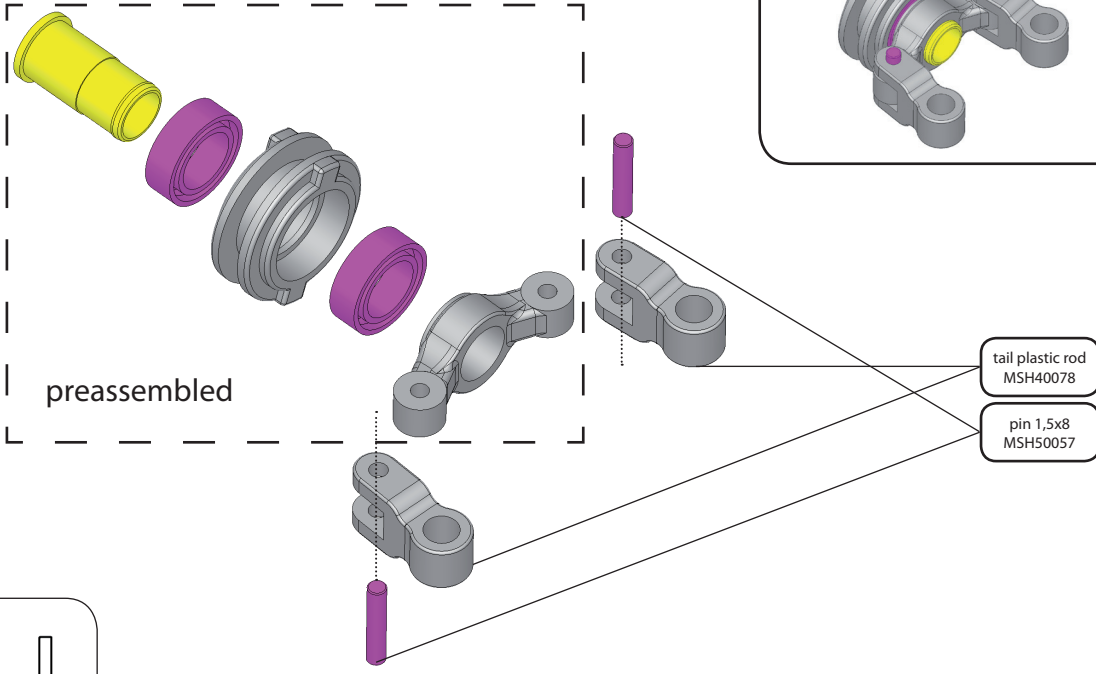

- pin 1,5x8
MSH50057

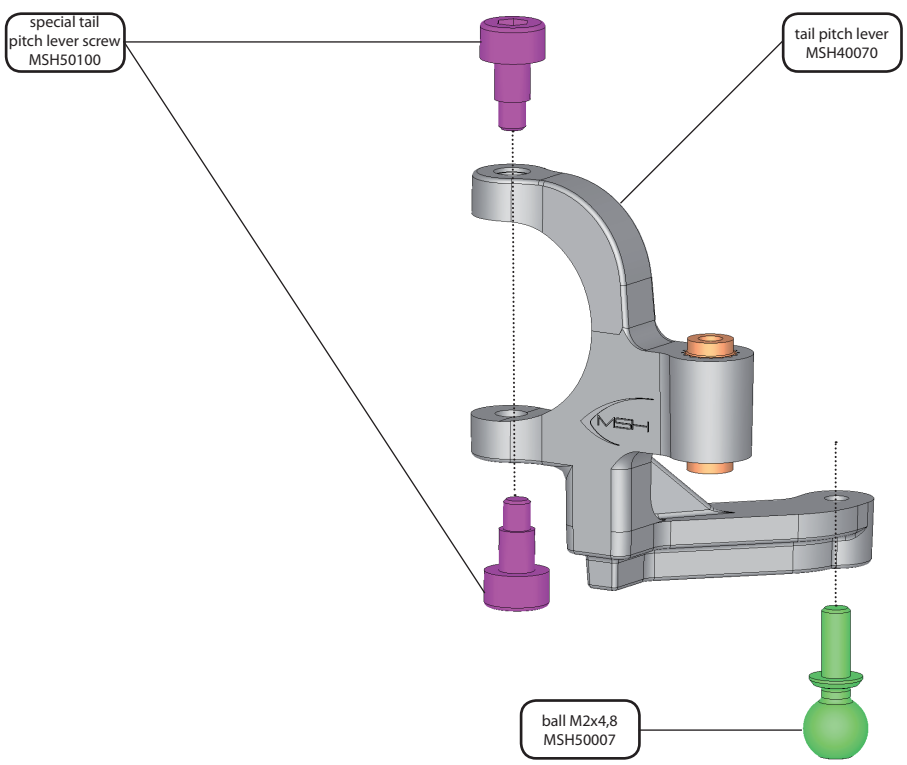

- special tail pitch lever screw
MSH50100
- ball M2x4,8
MSH50007

BAG F

1

2

3

4

follow steps in pics
carefully to insert lever in
position

BAG F

hex screw
M2x6
MSH50098

BB 2x5x2
MSH40005

LOCTITE
hex screw M2x6
MSH50098

BB 2x5x2
MSH40005

BAG F

1

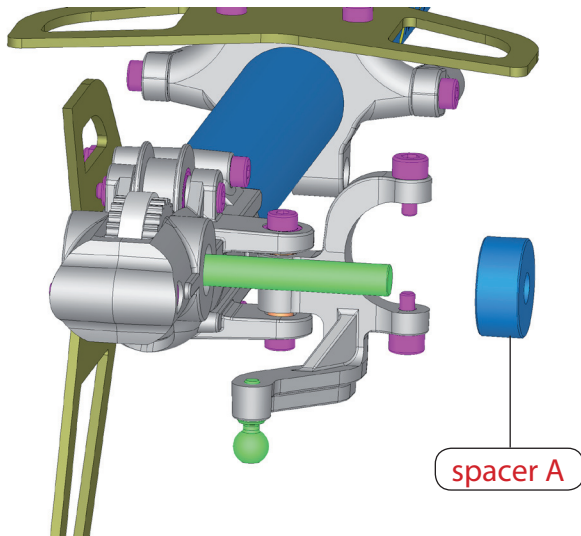

2

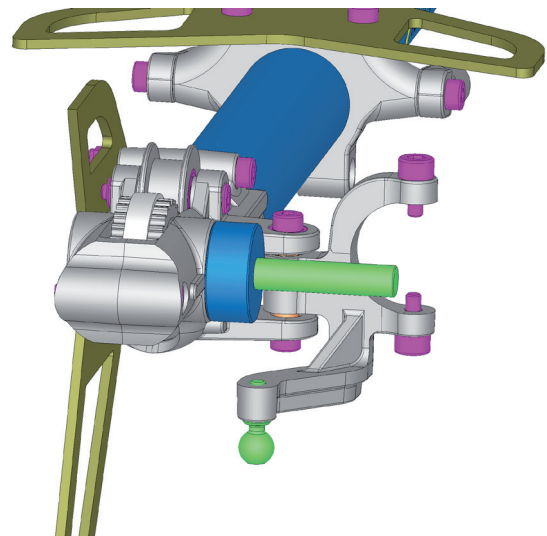

Insert **spacer A** on tail shaft and slide it to the left against the tail box. Turn the tail pitch lever until tail pitch lever special screws touch the **spacer A**. Check that both screws touch the spacer at the same time.

If one screw touches before gently twist the lever until they touch together.

Warming up lever makes job easier.

Remember to remove **spacer A** after the job is completed.

3

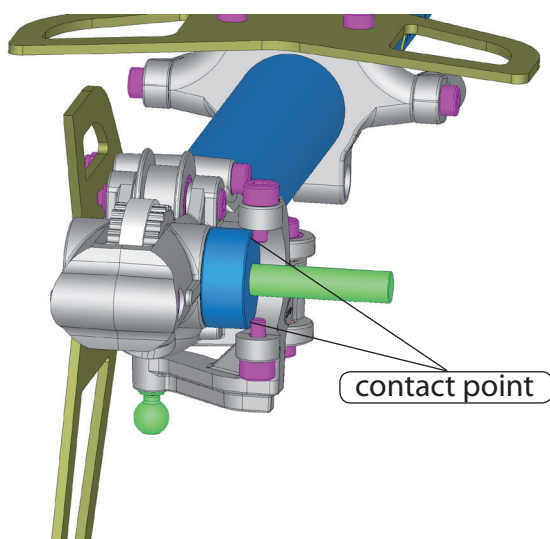

4

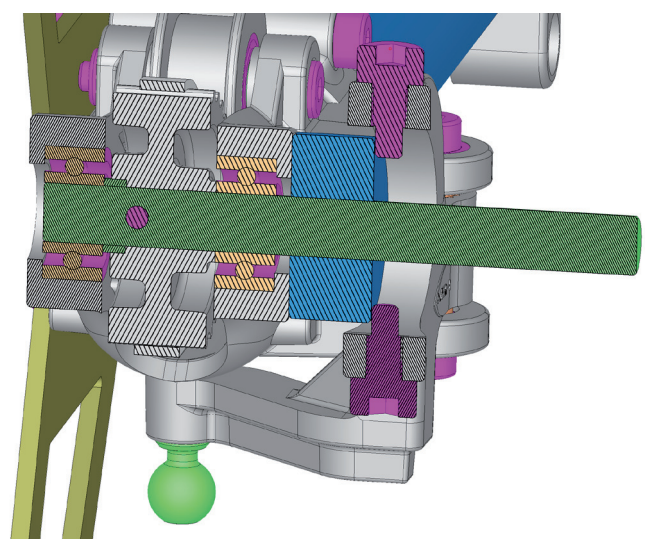

BAG F

BB 3x6x2,5
MSH50037



make sure BB are fully seated inside tail blade grip

tail blade holder
MSH40060

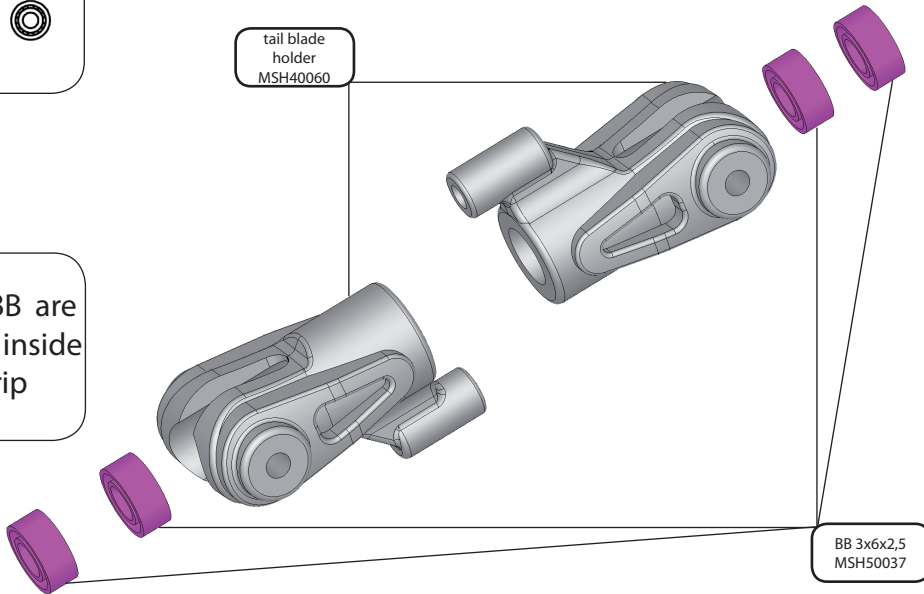

hex screw
grub M3x3
MSH50117



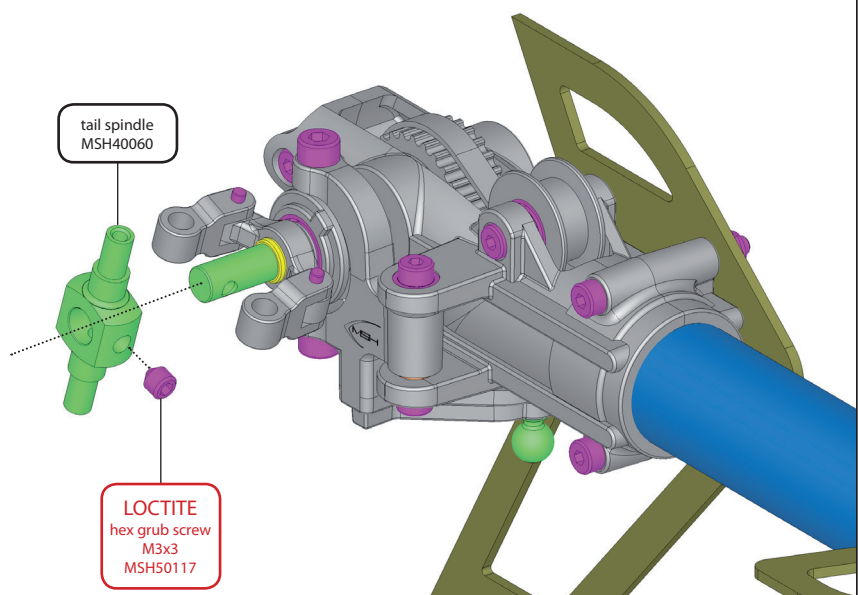

tail spindle
MSH40060

LOCTITE
hex grub screw
M3x3
MSH50117



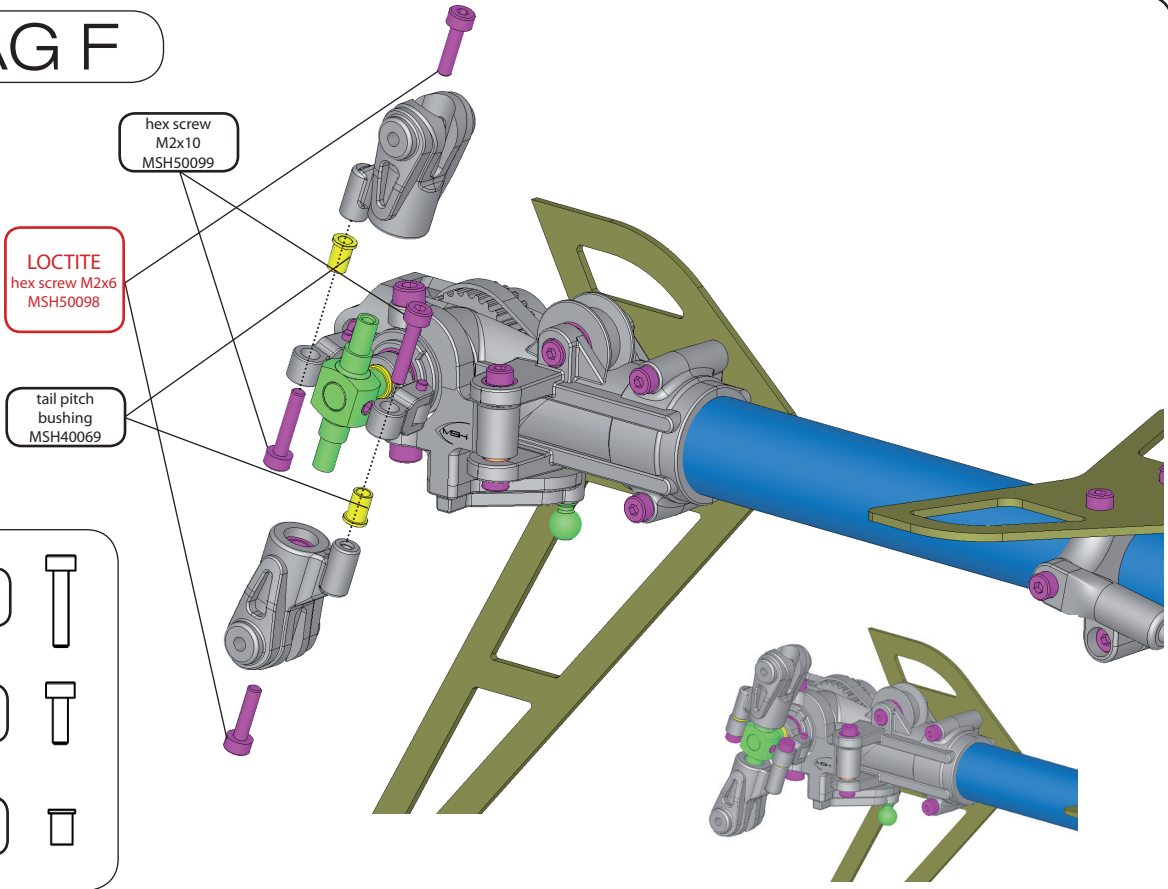

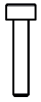
BAG F

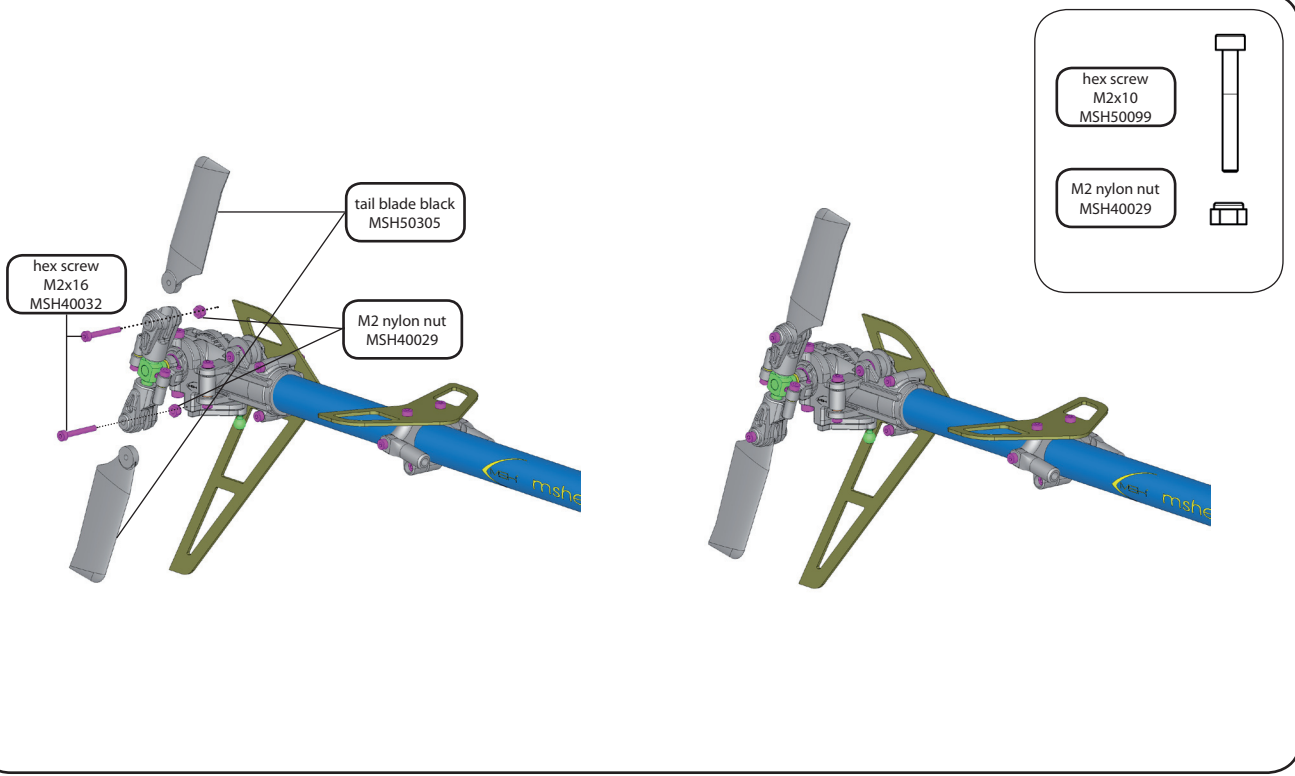

- hex screw M2x10 MSH50099 
- hex screw M2x6 MSH50098 
- tail pitch bushing MSH40069 



- hex screw M2x10 MSH50099 
- M2 nylon nut MSH40029 

BAG L

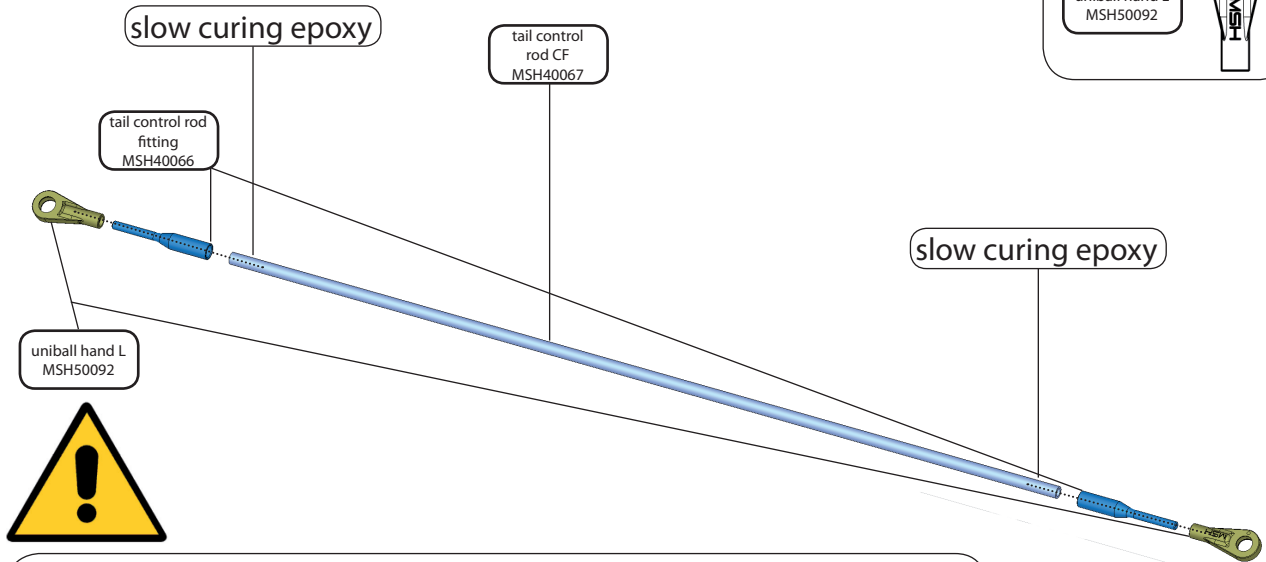

gently remove coating with sandpaper on 10mm at the end of control rod and boom brace.

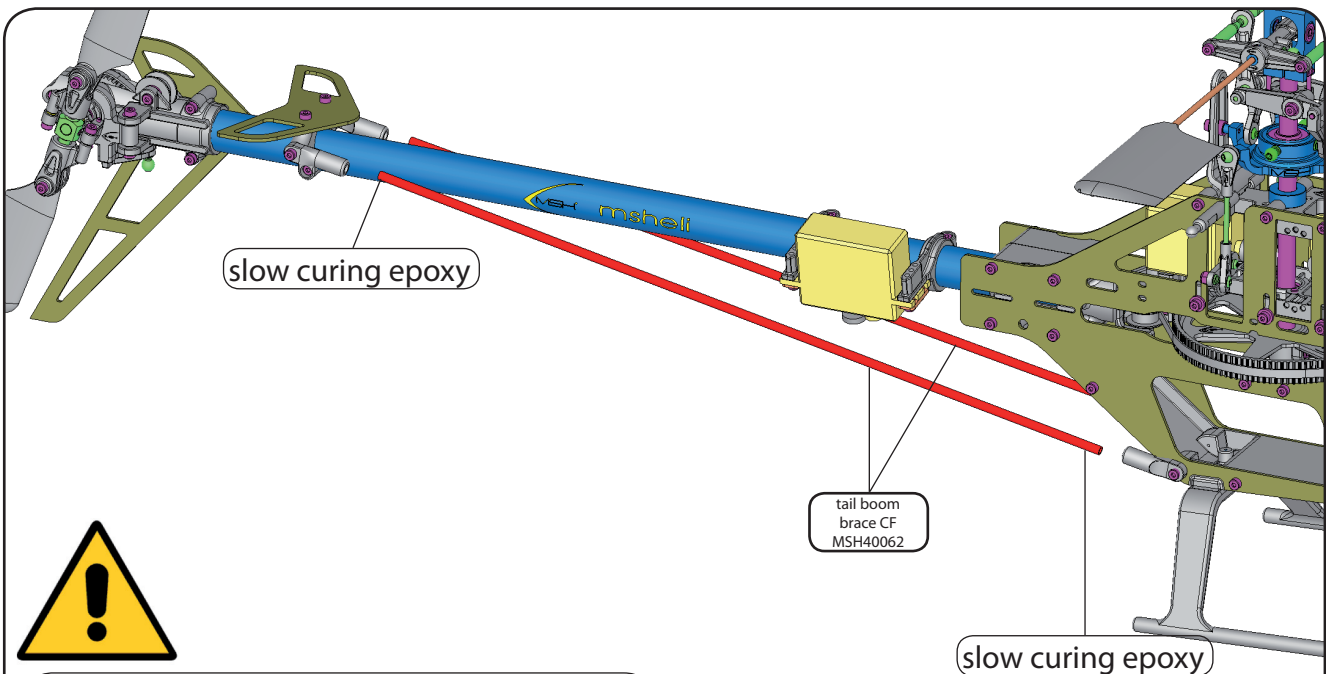

after the braces are in position with epoxy tighten the 4 screw at the brace rod ends. remember apply threadlock on the front ones.

BAG H



check for links smoothness
if tight use provided reamer

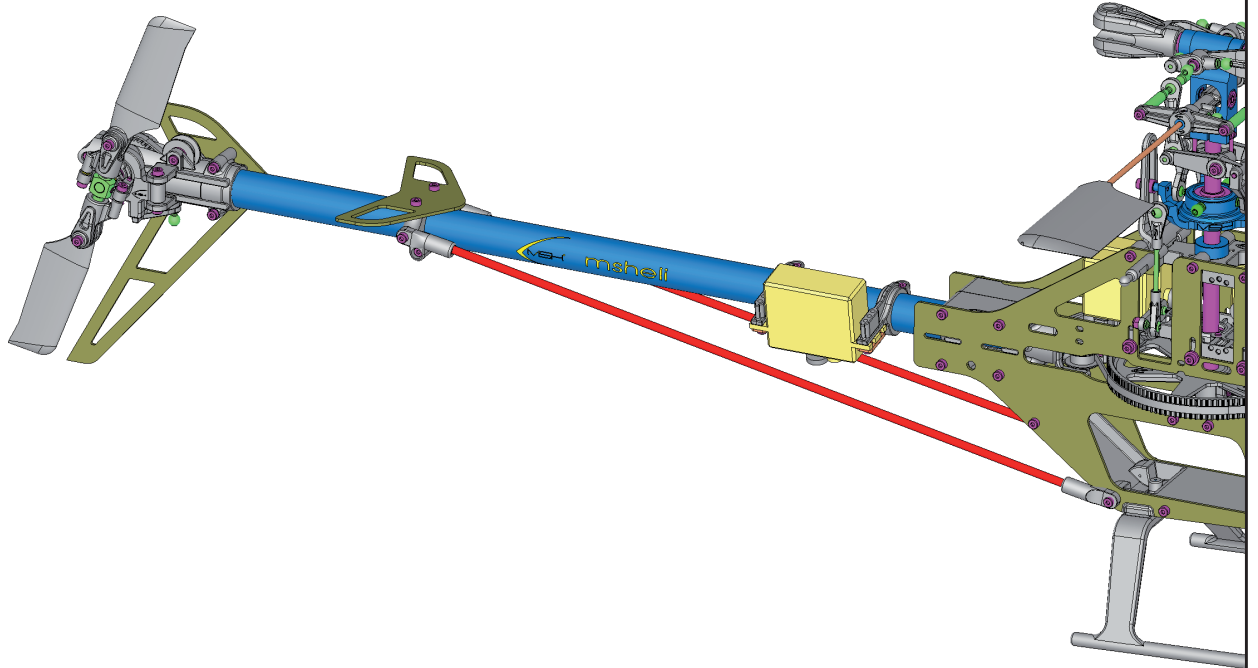
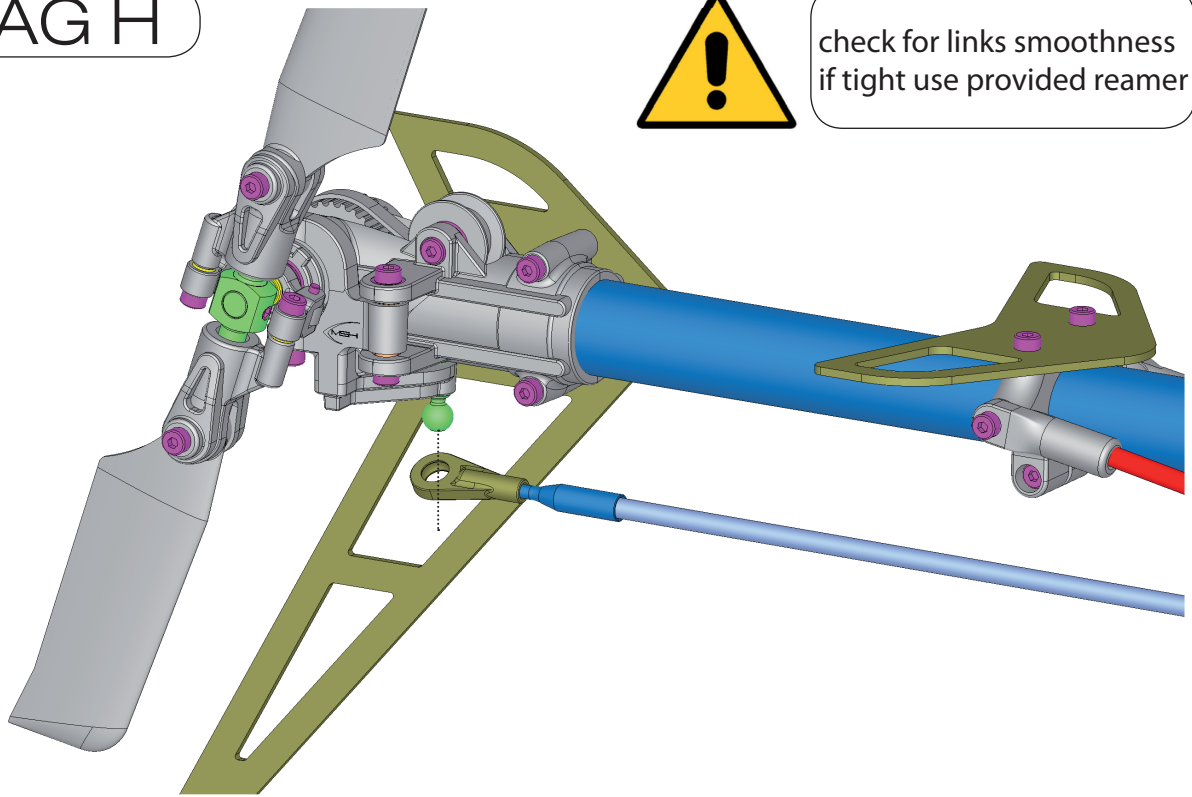

BAG H

hex screw
M3x6
MSH40097

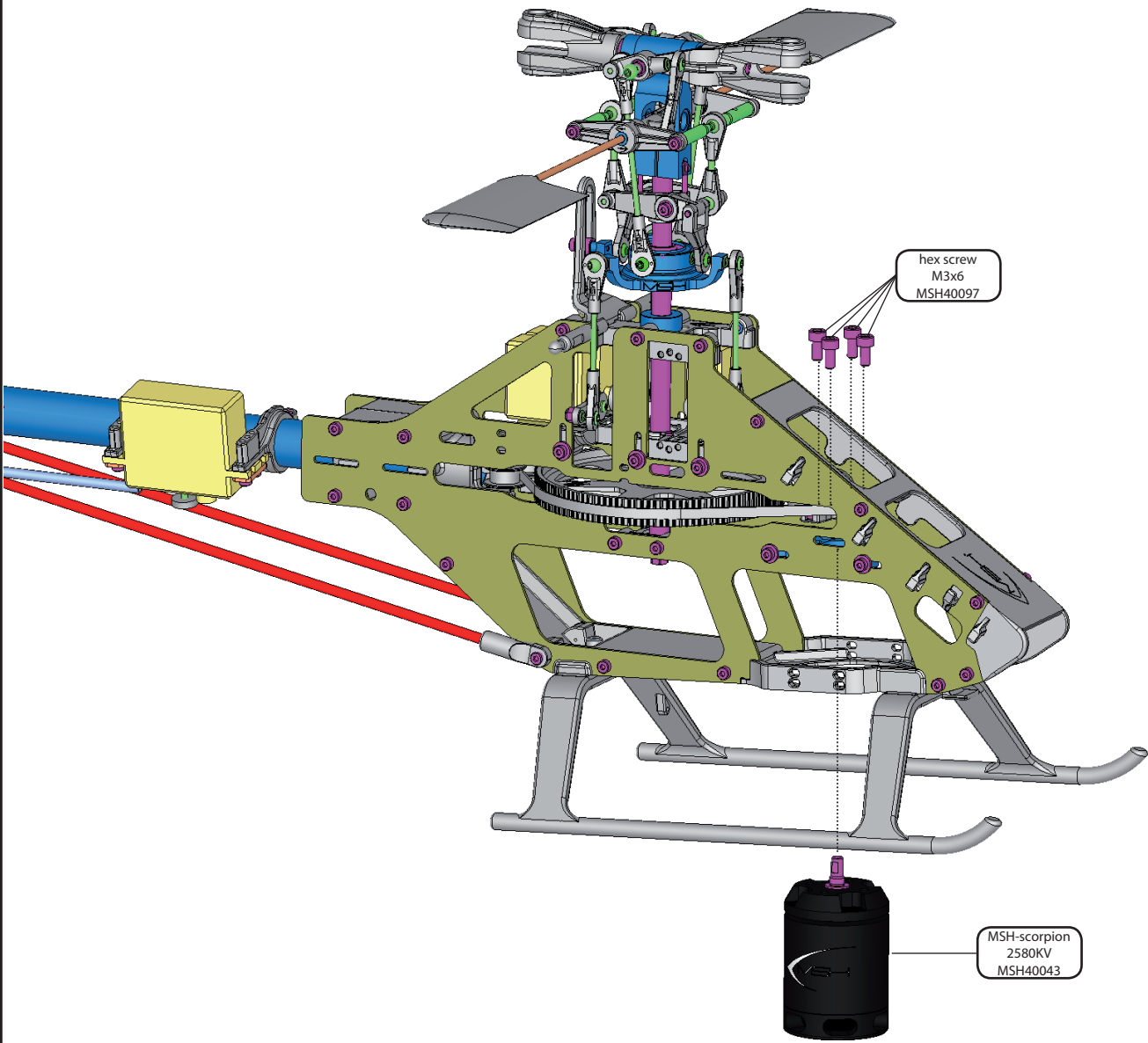

BAG H

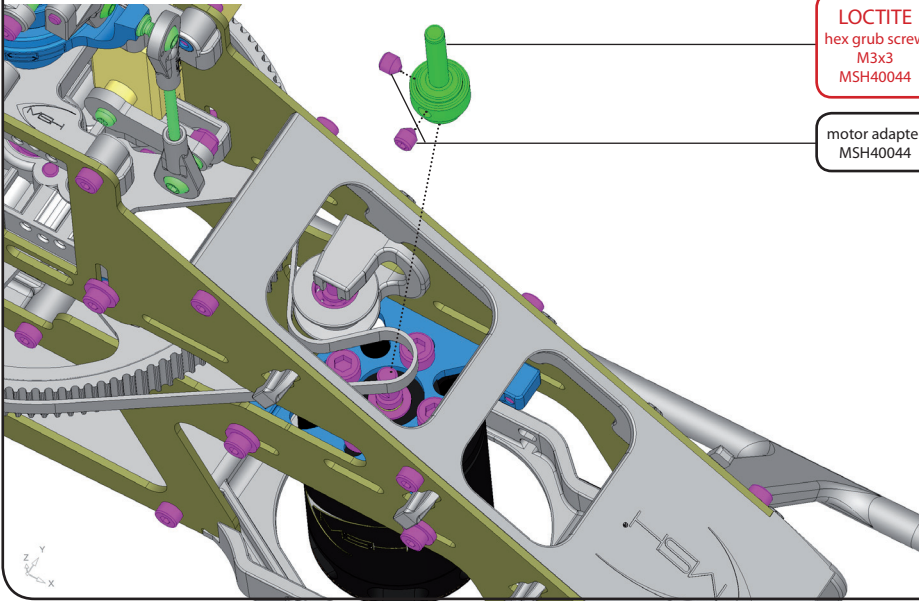

LOCTITE
hex grub screw
M3x3
MSH40044

motor adapter
MSH40044

motor adapter
MSH40044



hex grub screw
M3x3
MSH40044



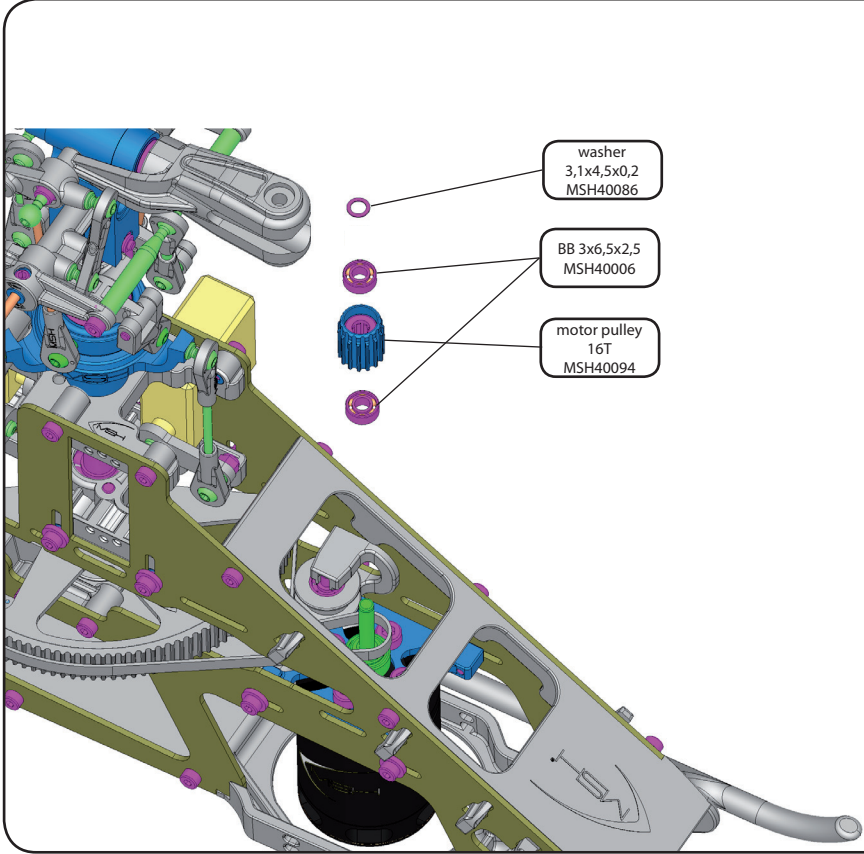

washer
3,1x4,5x0,2
MSH40086

BB 3x6,5x2,5
MSH40006

motor pulley
16T
MSH40094

BB 3x6,5x2,5
MSH40006



washer
3,1x4,5x0,2
MSH40086



BAG F

hex screw
M2x8
MSH40035



washer
3,1x4,5x0,2
MSH40086



LOCTITE
hex screw
M2x8
MSH40035

Y support
MSH40103

washer
2,1x5,5x1
MSH40085

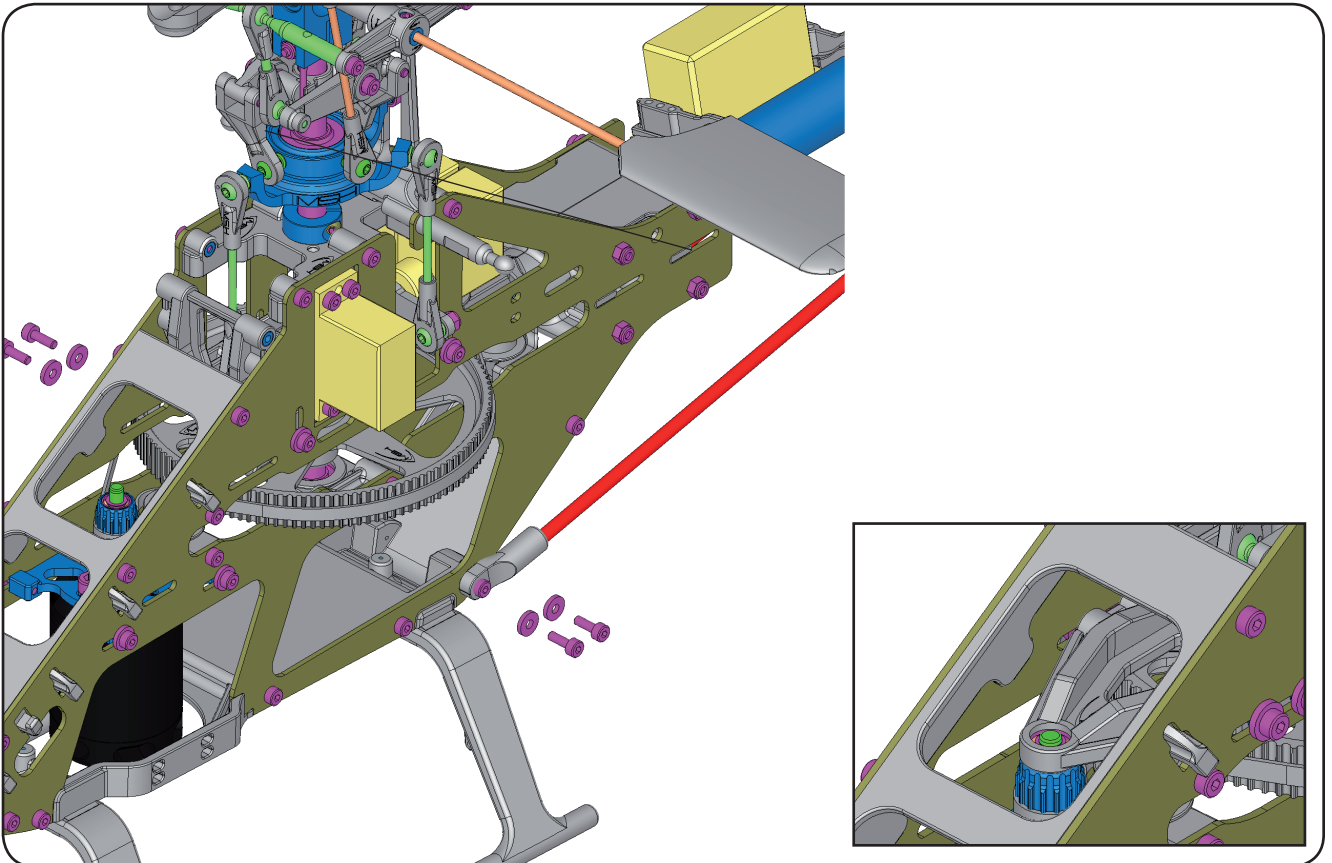
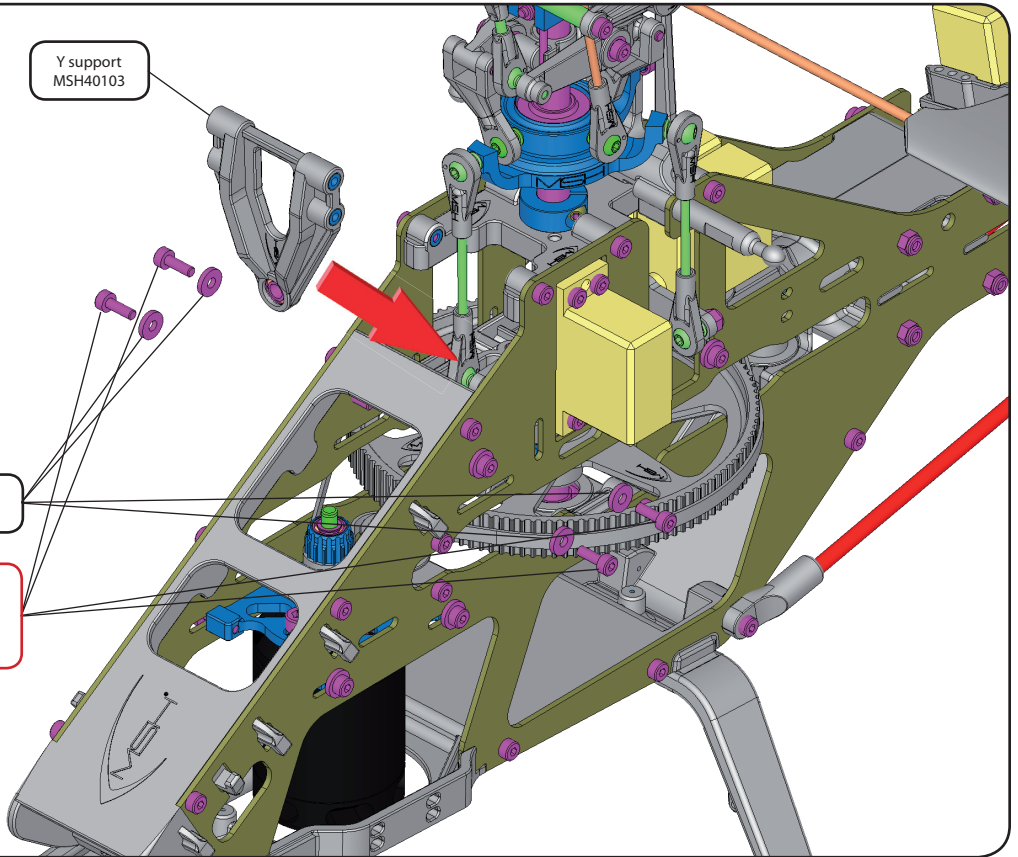

BAG M

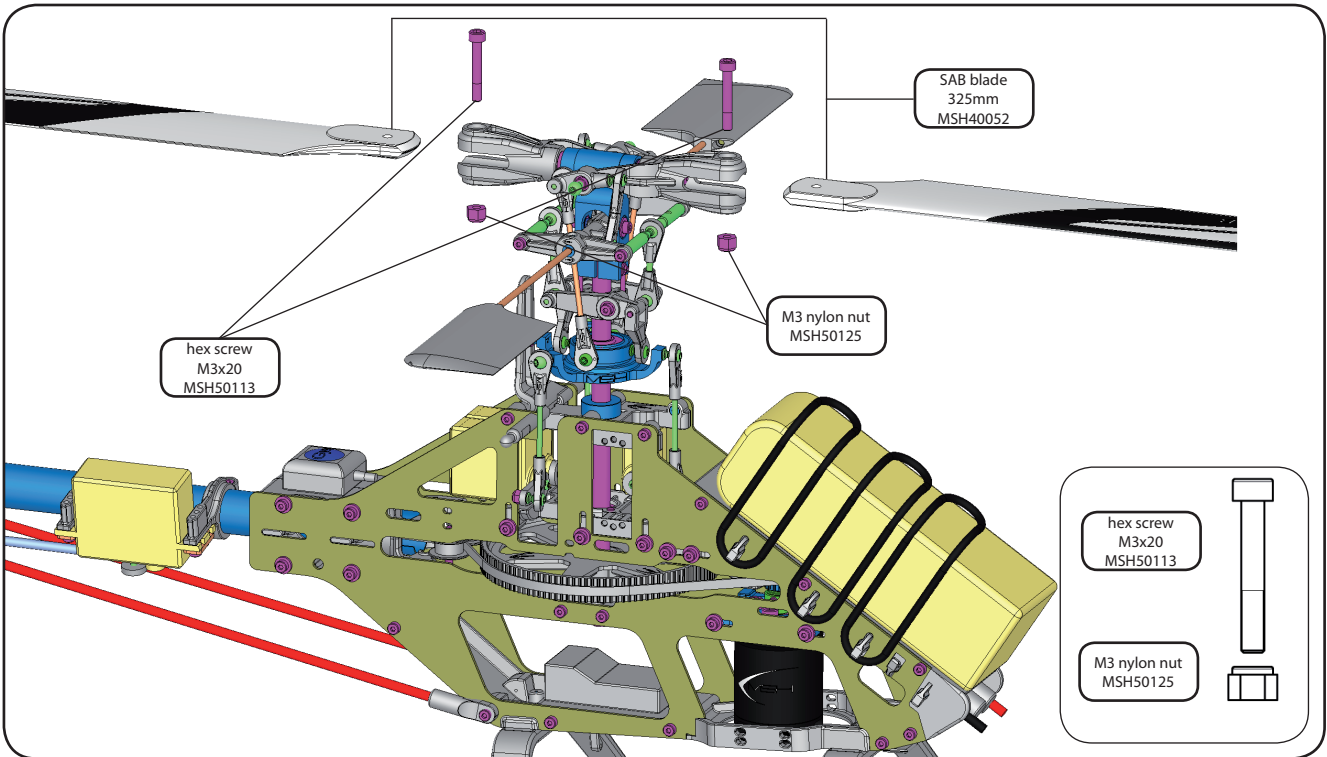
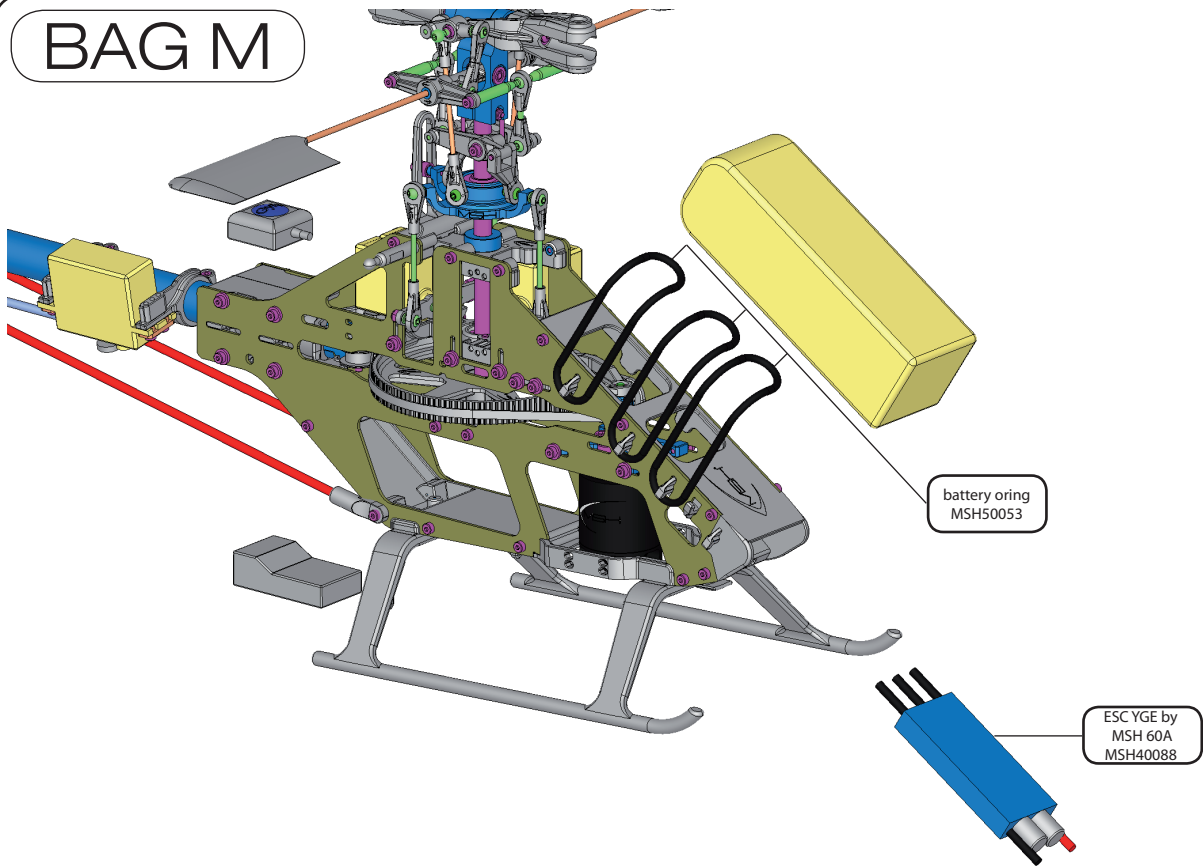

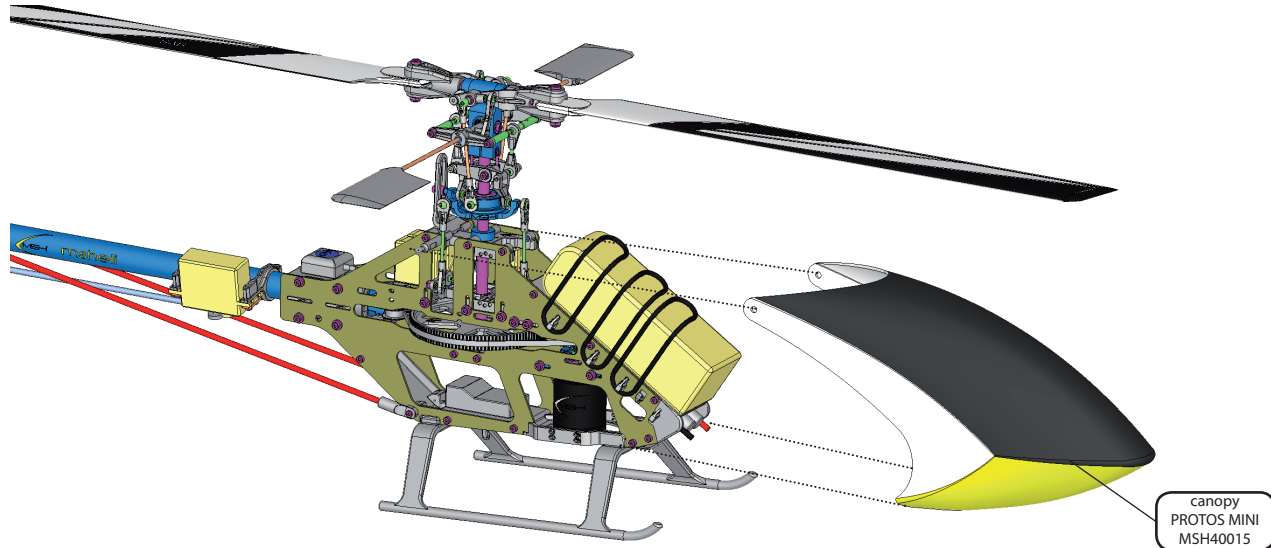

belt tension adjustment

Pressing the belt moderately, it should move 2-3 mm.
Test tension as indicated in the picture.

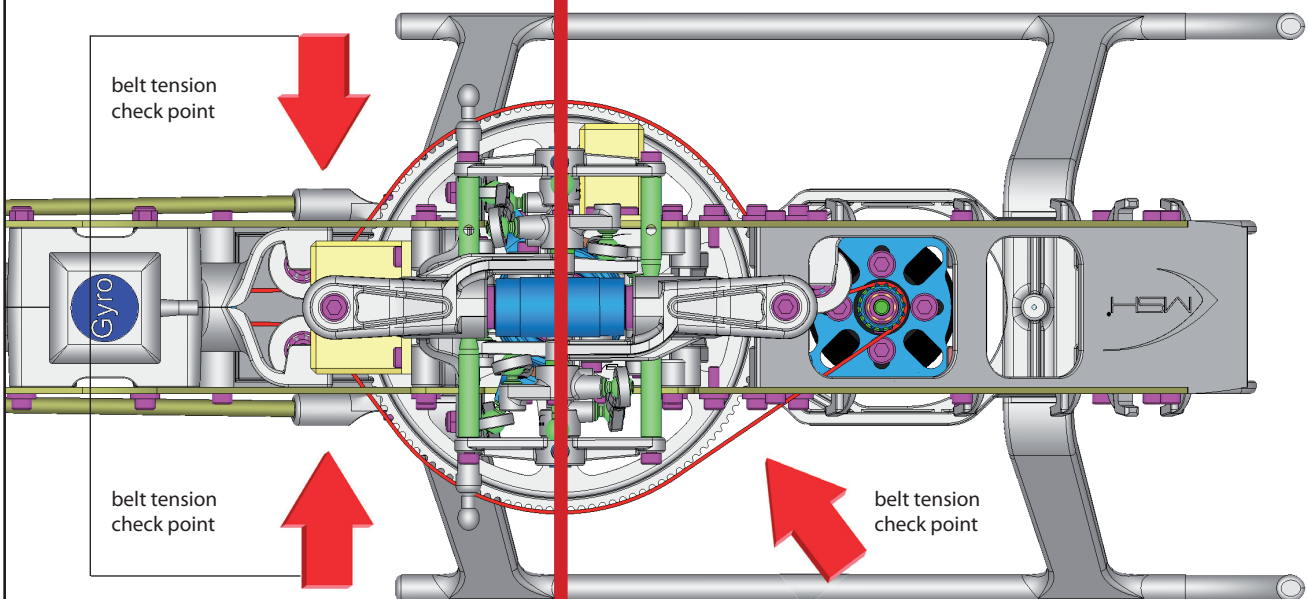

REAR TENSION ADJUSTMENT

FRONT TENSION ADJUSTMENT

Please make sure that belt tension is set properly on both sides.
Front and Rear tension is set independently !!

spare part list

Spare code	Spare description	Part Code	Part description	Part Qty
MSH41001	Flybar control arm	MSH50098	Hex screw M2x6	4
	Flybar control arm	MSH50117	Hex grub screw M3x3	4
	Flybar control arm	MSH40018	Flybar arm comolded	2
	Flybar control arm	MSH40017	Cross ball	2
MSH41002	Spindle	MSH50146	Washer 2.6x6.5x1.5	2
	Spindle	MSH40057	Spindle	2
	Spindle	MSH50103	Hex screw M2,5x8	2
MSH41003	Head dampeners	MSH40058	Spindle spacer	2
	Head dampeners	MSH40105	Dumper main head	2
	Head dampeners	MSH40102	Washer 6x8x0,1	6
MSH41004	Steel Main shaft Hollow	MSH50146	Washer 2.6x6.5x1.5	1
	Steel Main shaft Hollow	MSH40028	Hex screw M2,5x8 Exagonal Head	1
	Steel Main shaft Hollow	MSH40040	Main shaft hollow	2
MSH41006	Tail shaft	MSH50144	Pin 1,5x12	1
	Tail shaft	MSH40075	Tail shaft	1
	Tail shaft	MSH40073	Tail pulley	1
	Tail shaft	MSH40076	Tail shaft bushing	1
MSH41007	Motor adapter	MSH40086	Washer 3,1x4,5x0,2	1
	Motor adapter	MSH40044	Motor adapter	1
	Motor adapter	MSH50117	Hex grub screw M3x3	2
MSH41008	Flybar rod	MSH40020	Flybar rod	2
MSH41011	Landing gear	MSH50311	PT TR 450 Nero	1
MSH41014	Pinion 14T	MSH40006	BB 3x6,5x2,5	2
	Pinion 14T	MSH40047	Oneway BB 3x6,5x6	1
	Pinion 14T	MSH40093	Motor pulley 14T	1
	Pinion 14T	MSH40086	Washer 3,1x4,5x0,2	2
MSH41015	Pinion 15T	MSH40006	BB 3x6,5x2,5	2
	Pinion 15T	MSH40047	Oneway BB 3x6,5x6	1
	Pinion 15T	MSH40046	Motor pulley 15T	1
	Pinion 15T	MSH40086	Washer 3,1x4,5x0,2	2
MSH41016	Pinion 16T	MSH40006	BB 3x6,5x2,5	2
	Pinion 16T	MSH40047	Oneway BB 3x6,5x6	1
	Pinion 16T	MSH40094	Motor pulley 16T	1
	Pinion 16T	MSH40086	Washer 3,1x4,5x0,2	2
MSH41017	Pinion 17T	MSH40006	BB 3x6,5x2,5	2
	Pinion 17T	MSH40047	Oneway BB 3x6,5x6	1
	Pinion 17T	MSH40095	Motor pulley 17T	1
	Pinion 17T	MSH40086	Washer 3,1x4,5x0,2	2
MSH41018	Pinion 18T	MSH40006	BB 3x6,5x2,5	2
	Pinion 18T	MSH40047	Oneway BB 3x6,5x6	1
	Pinion 18T	MSH40096	Motor pulley 18T	1
	Pinion 18T	MSH40086	Washer 3,1x4,5x0,2	2
MSH41019	Main hub	MSH50041	BB 2x5x2,5 Flanged	2
	Main hub	MSH40031	Hex screw M2x14	1
	Main hub	MSH40029	M2 nylon nut	1
	Main hub	MSH40112	Main hub	1
	Main hub	MSH40105	Dumper main head	2
MSH41020	Swashplate	MSH50009	Ball M2x2,8	7
	Swashplate	MSH50021	Swashplate bushing	1
	Swashplate	MSH50039	BB 2x5x2,5	2
	Swashplate	MSH50099	Hex screw M2x10	1
	Swashplate	MSH40003	BB 15x21x4	1
	Swashplate	MSH40056	Spherical joint GE6C	1
	Swashplate	MSH40059	Swashplate	1
MSH41021	Washout hub	MSH50099	Hex screw M2x10	2
	Washout hub	MSH40083	Wash out hub	1
MSH41022	Head rods set	MSH50049	Rod B 12mm	2
	Head rods set	MSH40050	Rod 15,1mm	2
	Head rods set	MSH40051	Rod 48,8mm	2

MSH41023	Servo rods set	MSH50045	Rod E 35mm	3
MSH41024	Tail control rod set	MSH50092	Uniball hand L	2
	Tail control rod set	MSH40067	Tail control rod 3x2x222mm	1
	Tail control rod set	MSH40066	Tail control rod fitting	2
MSH41025	Boom	MSH40061	Boom	2
MSH41026	Tail boom brace	MSH40062	Tail boom brace 3x2x272mm	2
	Tail boom brace	MSH40014	Brace rod end	4
MSH41027	Washout control arm	MSH50007	Ball M2x4,8	2
	Washout control arm	MSH50039	BB 2x5x2,5	4
	Washout control arm	MSH50058	Pin 2x12	2
	Washout control arm	MSH40012	BB Spacers	2
	Washout control arm	MSH40082	Wash out arm	2
	Washout control arm	MSH40084	Wash out uniball arm	2
MSH41028	Washout uniball arm	MSH40084	Wash out uniball arm	2
MSH41029	Washout arm	MSH40082	Wash out arm	2
MSH41032	Tail pitch assembly	MSH50057	Pin 1,5x8	2
	Tail pitch assembly	MSH40010	BB 5x8x2,5	2
	Tail pitch assembly	MSH40055	Slide shaft	1
	Tail pitch assembly	MSH40071	Tail pitch plate	1
	Tail pitch assembly	MSH40072	Tail pitch plate boss	1
	Tail pitch assembly	MSH40078	Tail plastic rod	2
MSH41033	Tail guide pulley	MSH40021	Guide pulley	1
	Tail guide pulley	MSH40068	Tail guide pulley bushing	1
	Tail guide pulley	MSH40007	BB 4x7x2,5	2
MSH41034	Guide pulleys	MSH40021	Guide pulley	3
	Guide pulleys	MSH40049	Pin 2,5x12	3
	Guide pulleys	MSH40038	BB 2,5x7x2,5	6
MSH41035	Belt	MSH40013	Belt	1
MSH41038	Tail blades	MSH50305	Gorilla gear tail blade black	2
MSH41039	4,5mm Main blade holders	MSH50099	Hex screw M2x10	2
	4,5mm Main blade holders	MSH50125	M3 nylon nut	2
	4,5mm Main blade holders	MSH40008	BB 4x8x3	4
	4,5mm Main blade holders	MSH40036	Hex screw M3x20 6mm threaded	2
	4,5mm Main blade holders	MSH40080	Thrust BB 4x8x3,5	2
	4,5mm Main blade holders	MSH40037	Main blade holder	2
	4,5mm Main blade holders	MSH40087	Washer 4,1x6x0.2	2
MSH41040	Mixers	MSH50007	Ball M2x4,8	4
	Mixers	MSH50039	BB 2x5x2,5	4
	Mixers	MSH50099	Hex screw M2x10	2
	Mixers	MSH40012	BB Spacers	2
	Mixers	MSH40041	Mixer	2
MSH41041	Servo frames	MSH50101	Hex screw M2,5x5	2
	Servo frames	MSH40011	BB 6x12x4	2
	Servo frames	MSH40085	Washer 2.1x5.5x1	6
	Servo frames	MSH40054	Servo frame comolded	2
	Servo frames	MSH40030	Hex grub screw M3x12	2
	Servo frames	MSH50098	Hex screw M2x6	6
	Servo frames	MSH40035	Hex screw M2x8	18
MSH41042	Antispin and front pulley holder	MSH50098	Hex screw M2x6	2
	Antispin and front pulley holder	MSH40001	Anti swashplate spin	1
	Antispin and front pulley holder	MSH40022	Guide pulley support	1
MSH41043	Flybar carrier	MSH50039	BB 2x5x2,5	2
	Flybar carrier	MSH50098	Hex screw M2x6	2
	Flybar carrier	MSH40019	Flybar carrier	1
MSH41044	Tail box	MSH40009	BB 4x9x4	2
	Tail box	MSH40031	Hex screw M2x14	2
	Tail box	MSH40033	Hex screw M2x20	2
	Tail box	MSH40029	M2 nylon nut	4
	Tail box	MSH40064	Tail Box L	1
	Tail box	MSH40065	Tail Box R	1
MSH41045	Tail pitch lever	MSH50007	Ball M2x4,8	1
	Tail pitch lever	MSH50098	Hex screw M2x6	2
	Tail pitch lever	MSH50100	M2,5x5 Special tail pitch lever screw	2
	Tail pitch lever	MSH40005	BB 2x5x2	2
	Tail pitch lever	MSH40070	Tail pitch lever	1

MSH41045	Tail pitch lever	MSH50007	Ball M2x4,8	1
	Tail pitch lever	MSH50098	Hex screw M2x6	2
	Tail pitch lever	MSH50100	M2,5x5 Special tail pitch lever screw	2
	Tail pitch lever	MSH40005	BB 2x5x2	2
	Tail pitch lever	MSH40070	Tail pitch lever	1
MSH41046	Tail rotor	MSH50037	BB 3x6x2,5	4
	Tail rotor	MSH50117	Hex grub screw M3x3	1
	Tail rotor	MSH40032	Hex screw M2x16	2
	Tail rotor	MSH40029	M2 nylon nut	2
	Tail rotor	MSH40060	Tail blade holder	2
	Tail rotor	MSH40069	Tail pitch bushing	2
	Tail rotor	MSH40077	Tail spindle	1
	Tail rotor	MSH50098	Hex screw M2x6	2
	Tail rotor	MSH50099	Hex screw M2x10	2
MSH41047	Tail blade holders	MSH40060	Tail blade holder	2
MSH41048	Tail spindle	MSH50117	Hex grub screw M3x3	1
	Tail spindle	MSH40077	Tail spindle	1
	Tail spindle	MSH50098	Hex screw M2x6	2
MSH41049	Fin set assembly CF	MSH50098	Hex screw M2x6	2
	Fin set assembly CF	MSH50099	Hex screw M2x10	3
	Fin set assembly CF	MSH40024	Horizontal fin CF	1
	Fin set assembly CF	MSH40029	M2 nylon nut	1
	Fin set assembly CF	MSH40023	Horizontal fin clamp	1
	Fin set assembly CF	MSH40081	Vertical fin CF	1
MSH41050	Fin set CF	MSH40024	Horizontal fin CF	1
	Fin set CF	MSH40081	Vertical fin CF	1
MSH41051	Tail servo holder	MSH50086	Servo adapter complete	1
	Tail servo holder	MSH40074	Tail servo holder	2
	Tail servo holder	MSH50099	Hex screw M2x10	2
	Tail servo holder	MSH40035	Hex screw M2x8	4
MSH41052	Main Pulley	MSH40031	Hex screw M2x14	1
	Main Pulley	MSH40029	M2 nylon nut	1
	Main Pulley	MSH40039	Main pulley	1
MSH41055	Canopy mounting post	MSH40030	Hex grub screw M3x12	2
	Canopy mounting post	MSH40016	Canopy stand	2
MSH41056	Tail boom case	MSH50118	Viti zincate 2.2x9,5	2
	Tail boom case	MSH40034	Hex screw M2x36	4
	Tail boom case	MSH40029	M2 nylon nut	4
	Tail boom case	MSH40063	Tail boom clamp	2
MSH41057	Motor mount	MSH40035	Hex screw M2x8	4
	Motor mount	MSH40085	Washer 2.1x5.5x1	4
	Motor mount	MSH40045	Motor mount	1
	Motor mount	MSH40097	Hex screw M3x6	4
MSH41061	Blade sponge holder	MSH40090	Main Blade Sponge Holder	1
MSH41062	SAB main blades CF	MSH40052	SAB Main blade 325	1
MSH41063	Scorpion motor 2580Kv	MSH40043	Scorpion MSH HK2221 2580Kv	1
MSH41000	Battery and ESC oring set	MSH50060	Oring 27x2,62	2
	Battery and ESC oring set	MSH40099	Oring 52.07x2.62	4
MSH41065	Thrust_BB_4x8x3,5	MSH40080	Thrust BB 4x8x3,5	2
MSH41066	BB 2x5x2,5	MSH50039	BB 2x5x2,5	4
MSH41067	BB_2e5x7x2e5	MSH40038	BB 2,5x7x2,5	2
MSH41068	BB_2x5x2	MSH40005	BB 2x5x2	2
MSH41069	BB_3x6e5x2e5	MSH40006	BB 3x6,5x2,5	2
MSH41070	BB_4x7x2e5	MSH40007	BB 4x7x2,5	2
MSH41071	BB_4x8x3	MSH40008	BB 4x8x3	4
MSH41072	BB_4x9x4	MSH40009	BB 4x9x4	2
MSH41073	BB_5x8x2e5	MSH40010	BB 5x8x2,5	2
MSH41074	BB_6x12x4	MSH40011	BB 6x12x4	2
MSH41080	Steel main shaft solid	MSH50146	Washer 2.6x6.5x1.5	1
	Steel main shaft solid	MSH40028	Hex screw M2,5x8 Exagonal Head	1
	Steel main shaft solid	MSH40101	Main shaft pieno	2

MSH41082	Servo frames PLASTIC ONLY	MSH40054	Servo frame comolded	2
MSH41084	Mixers PLASTIC ONLY	MSH40041	Mixer	2
MSH41085	4,5mm Main blade holder PLASTIC ONLY	MSH40037	Main blade holder	2
MSH41086	Tail box PLASTIC ONLY	MSH40064	Tail Box L	1
	Tail box PLASTIC ONLY	MSH40065	Tail Box R	1
MSH41087	Flybar carrier (2 pcs) PLASTIC ONLY	MSH40019	Flybar carrier	2
MSH41092	CF Frame plates	MSH40025	Carbon frame L	1
	CF Frame plates	MSH40026	Carbon frame R	1
MSH41093	ESC MSH by YGE 60 A	MSH40088	ESC YGE by MSH 60 A	1
MSH41091	Carbon frame - Plastic parts	MSH40002	Battery plate	1
	Carbon frame - Plastic parts	MSH40027	Lower plate	1
	Carbon frame - Plastic parts	MSH40079	Third bearing support	1
MSH41081	Painted canopy FG Classic Scheme	MSH40015	Canopy protos	1
MSH41009	Ball M2x4,8	MSH50007	Ball M2x4,8	5
MSH41010	Ball M2x2,8	MSH50009	Ball M2x2,8	5
MSH41030	Uniball Link L	MSH50092	Uniball hand L	10
MSH41031	Uniball Link S	MSH50096	Uniball hand S	10
MSH41036	Paddles	MSH50062	Paddle weight	2
	Paddles	MSH50088	Paddle	2
MSH41037	Servo adapter set	MSH50086	Servo adapter complete	1
MSH41094	Flybarless long stand uniball	MSH40107	Ball Long stand grips FBL	2
	Flybarless long stand uniball	MSH40110	Main blade washer FBL	2
MSH41095	Flybarless swashplate ball	MSH50175	Ball swashplate FBL	3
MSH41096	Flybarless spindle kit	MSH40108	Long spindle FBL	1
	Flybarless spindle kit	MSH50146	Washer 2.6x8.5x1.5	2
	Flybarless spindle kit	MSH50103	Hex screw M2,5x8	2
MSH41097	Head dampers flybarless	MSH40109	Spindle spacers large FBL	2
	Head dampers flybarless	MSH40105	Dumper main head	2
MSH41098	Control washout arm flybarless	MSH50201	Wash out arm FBL	2
	Control washout arm flybarless	MSH50058	Pin 2x12	2
	Control washout arm flybarless	MSH40084	Wash out uniball arm	2
	Control washout arm flybarless	MSH40012	BB Spacers	2
	Control washout arm flybarless	MSH50039	BB 2x5x2,5	4
MSH41099	Washout arm flybarless	MSH40104	Wash out arm FBL	2
MSH41100	Horizontal clamp	MSH40023	Horizontal fin clamp	1
	Horizontal clamp	MSH40029	M2 nylon nut	1
	Horizontal clamp	MSH50098	Hex screw M2x6	2
	Horizontal clamp	MSH50099	Hex screw M2x10	3
MSH41101	Landing gear orange	MSH50341	PT TR 450 Orange	1
MSH41102	Ball sizer	MSH50136	Ball sizer	1
MSH41075	BB 3x6x2,5	MSH50037	BB 3x6x2,5	4
MSH41077	BB 2x5x2,5 Flanged	MSH50041	BB 2x5x2,5 Flanged	2

MSHeli s.r.l.
Saronno (VA)
ITALY

specification and design are subject to change without notice

LOCTITE are a registred mark